



## **OPMI Lumera i from ZEISS**

Brilliant Red Reflex.  
Efficient Workflow.



We make it visible.

# Precision

## All the Details of the Patient's Eye

With Stereo Coaxial Illumination (SCI), OPMI Lumera® i from ZEISS incorporates a revolutionary technology for red reflex. Contours appear razor sharp. See intricacies of the ocular anatomy and details of the patient's eye more vividly and brilliantly than ever before.

### **A stable red reflex without compromises**

The surgical area shines brightly and vividly, even with strongly pigmented, decentered and ametropic eyes when viewed through the ZEISS OPMI Lumera i.

### **Better depth of field means fewer adjustments**

DeepView, the integrated depth of field management system allows you to optimize the microscope in seconds. At the push of a button, switch between maximum light transmission and maximum depth of field – whichever best suits the situation.

### **Light without interruption**

The system automatically detects a defective halogen bulb and immediately turns on the backup bulb, eliminating the time required for manual replacement.

*Unique contrast and outstanding brilliance thanks to SCI: comparison of red reflexes.  
(Cincinnati Eye Institute, OH, USA)*

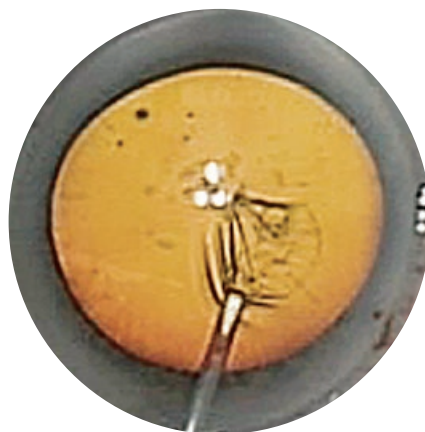

*ZEISS OPMI Lumera i*

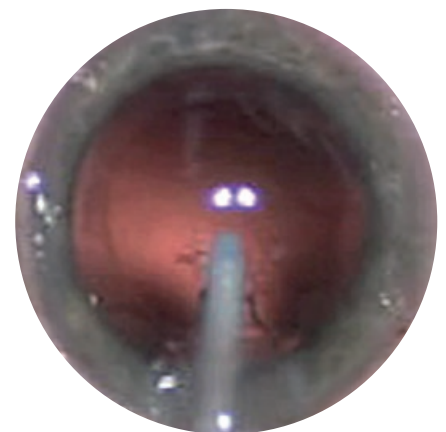

*Conventional microscope*



# Performance

## Your Ergonomics – Perfectly Integrated

Integration is the epitome of the ZEISS OPMI Lumera i. The video camera control unit and most of the microscope's cables are incorporated into the stand. As part of an optimal workflow, the image of the surgical field can be directly transmitted to a monitor in the operating room or into another room, allowing live monitoring of the procedure and helping the workflow by providing everyone with the same information.

### Centrally controlled

ZEISS OPMI Lumera i adjusts to your needs, not the other way around. With the microscope's touchscreen you can control both the microscope and the video camera. The display is easy to use and can be easily accessed during an operation.



*Touchscreen control*

### Simultaneous viewing

ZEISS OPMI Lumera i can be equipped with a stereo co-observation tube. This enables a second person to see the surgical field at the same magnification level. This is particularly well suited for sterile assistants or for training.

### React individually and hands-free

The ergonomically designed foot control panel (wireless or wired) easily enables you to control ZEISS OPMI Lumera i precisely and reliably. You can custom configure the buttons according to your personal preferences.

### Easy sterility recognition

ZEISS OPMI Lumera i addresses every detail. The blue colored, resterilizable asepsis caps are a perfect example; they enable you to recognize whether control surfaces are sterile or non-sterile.

### Rapid change for cataract or retina

With the optional Invertertube®, conversions are no longer required when switching between cataract and retina surgeries.

### Freedom of movement even when OR space is scarce

The compact suspension system makes the ZEISS OPMI Lumera i ideal for smaller operating rooms such as those in ambulatory surgical centers.



*Freely configurable foot control panel*



# Wide Range of Accessories for Special Demands

Select the Configuration that is Tailored to the Needs of Your OR

## **MediLive Primo for video co-observation**

The compact and economical 1CCD video camera is ideal for showing video on a monitor – enabling staff or students to follow the operation.

## **MEDIALINK 100**

The MEDIALINK™ 100 makes documentation of surgeries simple. Record standard definition videos and capture still images that can then be automatically transferred to USB storage media or to a files server.

## **HD redefined with TRIO 610**

The high definition camera system with apochromatic video optics allows microscope images to be generated with enhanced resolution and color rendition. The camera can be used for information, documentation, teaching and presentation of high quality images.

## **MediLive Trio Eye for all ophthalmic video requirements**

The MediLive® Trio Eye video camera can be adjusted to different lighting conditions at the push of a button. It provides a bright, high-contrast image on the monitor during posterior segment procedures where little light is used. In the anterior segment, the videos provide details of the sclera without blooming.

## **View of the retina**

The RESIGHT® 500 from ZEISS fundus viewing system provides a clear, detailed view of the retina.

## **Invertertube for a fast change**

Slow, laborious conversions between cataract and retina surgery are a thing of the past. The Invertertube integrates inverter functionality into an ergonomically designed binocular tube, simplifying image inversion and allowing the surgeon to work in complete comfort.

## **Stereo co-observation tube for a second set of eyes**

The second viewing tube connected via a beam splitter enables assistants or students to directly view the surgical field and techniques of the surgeon.

## **FlexioStill™ adapter for use with compact cameras**

With this lightweight, easy-to-use adapter, a compact digital camera can quickly and easily become a part of the OPMI Lumera i surgical microscope.



MEDIALINK 100



ZEISS RESIGHT 500



Invertertube

# Patient Care

## Recognizing all Details Reliably

Patients trust in your surgical capabilities. ZEISS OPMI Lumera i complements your personal desire to provide premium medical care.

### Visualization

The SCI illumination technology in ZEISS OPMI Lumera i establishes an entirely new benchmark regarding contrast and brilliance. Recognize the slightest residual tissue in the capsular bag reliably and remove it properly. You can also see small but critical details during retinal procedures.

### RESIGHT 500

Incorporating renown apochromatic optics, the ZEISS RESIGHT 500 non-contact fundus viewing system provides a clear, detailed view of the retina.

### Automatic light control

The system automatically turns off the light when ZEISS OPMI Lumera i is placed in the standby position.

### Phototoxicity protection

Thanks to the optical concept of SCI illumination, very little light is required to generate the red reflex. This minimizes light exposure to the patient's eye. Furthermore, the full field illumination can be separately regulated so that the red reflex shines as brightly as possible and is not affected by scattered light. This creates greater visualization capabilities, while maximizing the surgeon's comfort, particularly during long, complicated surgeries.

*Cataract surgery:  
SCI enables you to recognize the  
slightest tissue residue in detail.*



*Retinal surgery:  
The high quality optics and light source  
allow you to see the retina in full detail.*





# Technical Data

## OPMI Lumera i from ZEISS

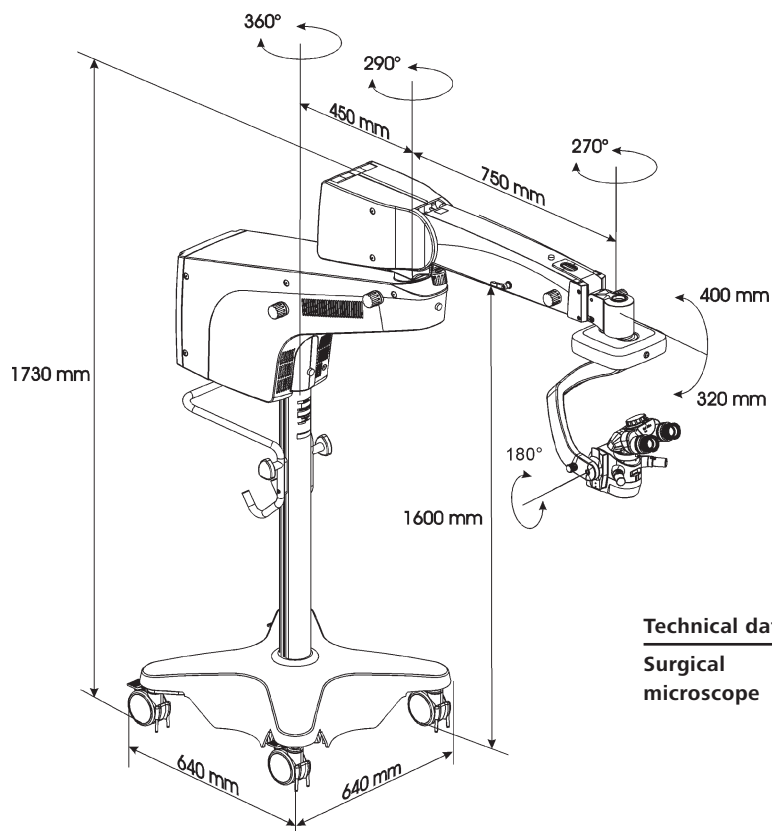

### Technical data

#### Surgical microscope

Apochromatic optics

Motorized zoom system, 1:6 zoom ratio, magnification factors  $\gamma = 0.4$  to 2.4

Focusing range: 50 mm

Binocular tube: 0-180° tiltable tube (optional Invertertube)

Eyepieces: 10 x (12.5 optional)

Objective lens  $f = 200$  mm ( $f = 175$  mm optional)

DeepView: depth of field management system

#### Illumination

SCI: red reflex illumination and full field illumination, both are adjustable, patent pending

Integrated 408 nm UV barrier filter

Blue blocking filter

Retinal protection device

Fiber optic illumination

Optional: fluorescence filter

#### Light source

12 V, 100 W halogen light source with fully automatic lamp change in case of lamp failure

#### X-Y coupling

61 mm x 61 mm adjustment range

Free programmable button for starting positions of X-Y coupling, focus and zoom, light

#### Weight

8.5 kg (with 180° inclinable binocular tube, objective lens and eyepieces)

#### Suspension system

Floor stand

Maximum load capacity: 14 kg (complete microscope equipment, including accessories)





The moment innovation and passion  
lead to the best vision for your patient.

**This is the moment we work for.**

// OPTHALMIC SOLUTIONS

MADE BY ZEISS



**Carl Zeiss Meditec AG**  
Goeschwitzer Strasse 51–52  
07745 Jena  
Germany  
[www.meditec.zeiss.com](http://www.meditec.zeiss.com)  
[www.meditec.zeiss.com/contacts](http://www.meditec.zeiss.com/contacts)

**EN\_30\_010\_010611 SUR.4512 Rev B** Printed in Germany AW-CZ-V/2014 Uoo  
The contents of the brochure may differ from the current status of approval of the product in your country. Please contact our regional representative for more information. Subject to change in design and scope of delivery and as a result of ongoing technical development.  
OPMI Lumera, Invertertube, MEDIALINK, RESIGHT, FlexioStill and MediLive are either trademarks or registered trademarks of Carl Zeiss Meditec AG.  
© Carl Zeiss Meditec AG, 2014. All copyrights reserved.