

Stemi 1000/2000/2000-C **Stereo Microscopes**

Operating Manual



Knowledge of this manual is required for the operation of the instrument. Would you therefore please make yourself familiar with the contents of this manual and pay special attention to hints concerning the safe operation of the instrument.

The specifications are subject to change; the manual is not covered by an update service.

- © Unless expressly authorized, forwarding and duplication of this document, and the utilization and communication of its contents are not permitted. Violations will entail an obligation to pay compensation.

All rights reserved in the event of granting of patents or registration of a utility model.

Issued by:



Carl Zeiss
Mikroskopie
D-07740 Jena
Telephone (**49) 03641 / 64-1616
Telefax: (**49) 03641 / 64-3144
Internet: mikro@zeiss.de
<http://www.zeiss.de>

Number of this
manual:

B 40-002 e

Date of issue:

12/98



TABLE OF CONTENTS

	Page
Title	
Copyright	
Table of contents	I
List of figures	III
Note	IV
General view	V
Notes on device safety	VII
1	DESCRIPTION
1.1	Designation, purpose 1-1
1.2	Description of the units 1-2
1.3	Technical data 1-4
1.4	Overview of modules 1-8
1.5	Function elements 1-29
2	OPERATION
2.1	Unpacking and setting up 2-1
2.2	Commissioning 2-3
2.2.1	Working with accessories 2-4
3	FLUORESCENCE CONTRAST WITH STEREO MICROSCOPES
3.1	FL S (Fluorescence for Stereo microscope) configuration 3-2
3.1.1	Name and intended application 3-2
3.2	Configurations 3-3
3.2.1	FL S configuration with KL 1500 electronic (not suitable for UV excitation) ... 3-4
3.2.2	FL S configuration with HBO 50 or HBO 100 3-6
3.2.3	FL S configuration with LUMATEC HBO 200 3-8



4	CARE AND TROUBLESHOOTING	
4.1	Care	4-1
4.2	Troubleshooting and service	4-2
		Page
 ANNEX		
–	List of abbreviations	A-3
–	Certification in accordance with DIN ISO 9001/EN 29001/EN 46001	A-5
–	EC conformity declaration	A-7

LIST OF FIGURES

	Page
Figure 1-1	Principal assemblies of the Stemi 2000-C 1-2
Figure 1-2	Optical schematic of the Stemi 2000-C 1-3
Figure 1-3	Basic microscope equipment 1-8
Figure 1-4	Eyepieces/eyepiece cups/reticules/attachment systems/specimen measuring plate 1-10
Figure 1-5	Stands 1-12
Figure 1-6	Specimen stages 1-14
Figure 1-7	Halogen lighting systems for vertical illumination 1-16
Figure 1-8	Cold light sources for vertical illumination 1-18
Figure 1-9	Halogen lighting systems for transmitted illumination 1-20
Figure 1-10	Cold light sources for transmitted illumination 1-22
Figure 1-11	Polarisation systems 1-24
Figure 1-12	Documentation systems using photo cameras 1-26
Figure 1-13	Adapters for video cameras 1-28
Figure 1-14	Function elements of the Stemi 2000-C 1-30
Figure 2-1	Stemi 2000-C packing unit in city box 2-1
Figure 2-2	Unpacking 2-2
Figure 2-3	Setting up the Stemi 2000-C 2-2
Figure 2-4	Adjusting the Stemi 2000-C 2-3
Figure 2-5	Inserting a graticule 2-4
Figure 2-6	Fitting an attachment system to the Stemi 2000 2-4
Figure 2-7	Mounting the polariser 2-5
Figure 2-8	Mounting a reflex camera 2-6
Figure 2-9	Mounting the microscope camera MC 80 for 35 mm photography 2-7
Figure 2-10	Mounting a video camera 2-8



	Page
Figure 3-1 Stemi 2000 with KL 1500 electronic	3-2
Figure 3-2 Stemi SV 6 with HBO 100	3-2
Figure 3-3 Stemi 2000 with HBO 50	3-2
Figure 3-4 Stemi SV 11 with LUMATEC HBO 200	3-2
Figure 3-5 FL S configuration with KL 1500 electronic	3-4
Figure 3-6	3-5
Figure 3-7	3-5
Figure 3-8	3-5
Figure 3-9	3-5
Figure 3-10 FL S configuration with HBO 50 or HBO 100	3-6
Figure 3-11	3-7
Figure 3-12	3-7
Figure 3-13	3-7
Figure 3-14	3-7
Figure 3-15 FL S configuration with LUMATEC HBO 200	3-8
Figure 3-16	3-9
Figure 3-17	3-9
Figure 3-18	3-9
Figure 3-19	3-9
Figure 3-20	3-10
Figure 3-21	3-10
Figure 4-1 Lamp replacement	4-2

NOTE

- The figures integrated in the text each have a figure number and a caption, e.g. "Fig. 2-8" signifies: the figure in Section 2 with the serial number 8. In each figure, details discussed in the text are assigned a reference line marking and an item number. In the running text, "T2 adapter (2-8/3)": in Fig. 8 of Section 2, the T2 adapter is marked with the item number 3.
- Refer to the annex for explanations of the abbreviations.
- This instruction manual refers to the Stemi 1000, Stemi 2000 or the Stemi 2000-C microscope versions (see Page 1-9) and their options.
Apply this manual analogously when working with other variants of the unit.

**GENERAL VIEW
(Basic unit)**

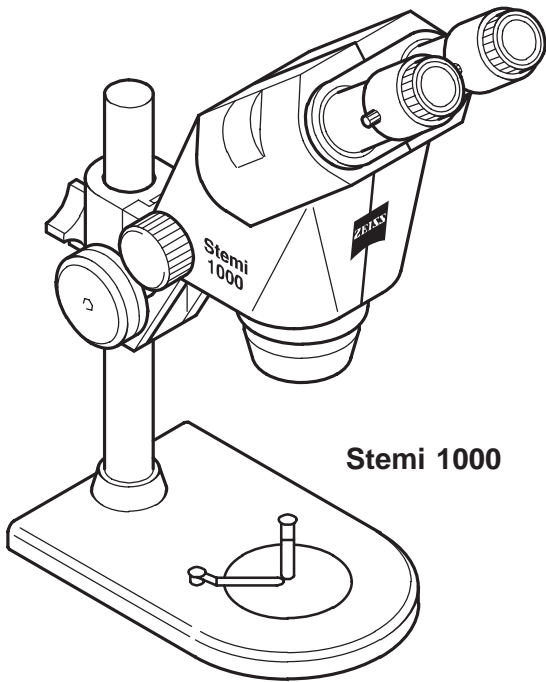

Stemi 1000

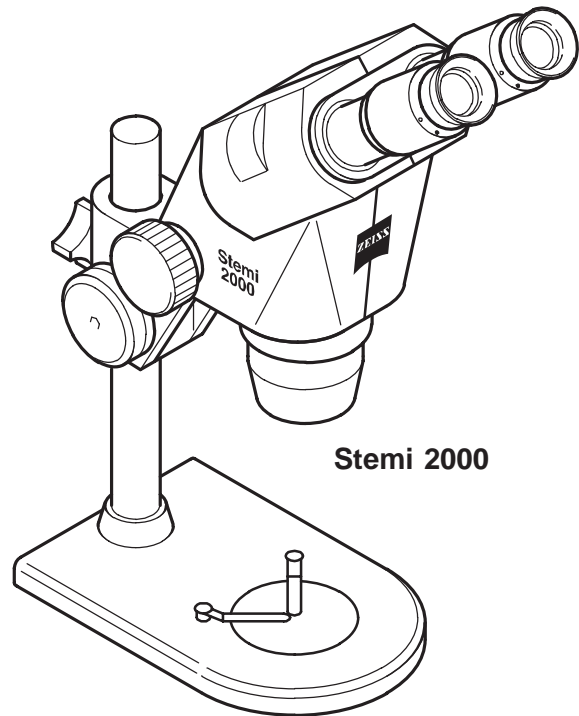

Stemi 2000

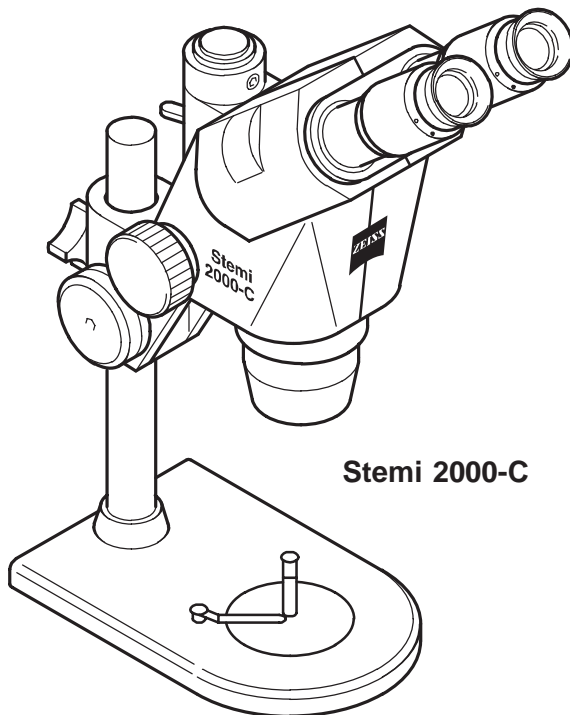

Stemi 2000-C



Stemi 1000, Stemi 2000, Stemi 2000-C

NEW MODEL

We have included a further Stemi model in our line of Greenough-type stereo microscopes.

In response to many requests received from customers, the

Stemi 2000-CS 45 50 55

is now also available as a brand-new item in addition to the Greenough-type stereo microscopes Stemi 1000, Stemi 2000 and Stemi 2000-C.

Unlike the Stemi 2000-C, the Stemi 2000-CS ("C" for "Camera" and "S" for "Splitter") features a

fixed camera port

with a 50/50 % beam splitting ratio, i. e. the camera port has no switching lever.

Unlike the Stemi 2000-C, the Stemi 2000-CS therefore provides the benefit of

simultaneous stereoscopic viewing

while taking photographs or working in the monitor mode.

All configurations or accessory components are identical to those of the other Stemi's.

NOTES OF DEVICE SAFETY

The Stemi 1000, Stemi 2000 or the Stemi 2000-C stereo microscope including original accessories or options must only be used for the microscopy applications described in this operating manual.

The manufacturer cannot assume any liability for any other applications, possibly also involving individual modules or single parts. This also applies to all service or repair work that is not carried out by authorised service personnel. All guarantee/warranty claims also expire for all those parts that were not directly affected by repair.

Particular attention must be paid to the following warning notes:

- ☞ The Stemi was designed and tested in conformity with the IEC Publication 1010-1 "Safety requirements for electrical measuring devices, control equipment and laboratory apparatus" and was delivered in a safe state. This operating manual contains information and warnings which must be followed by the operator.
- ☞ The Stemi is a light microscope conceived in accordance with the latest scientific and technical knowledge for visual, microphotographic and video analysis of microscopic specimens. The unit must only be used for the intended purpose. It is not intended for continuous unsupervised operation!
- ☞ The Stemi has no special facilities to protect against samples that have caustic, toxic, radioactive or other effects that are damaging to health.
- ☞ Users must check whether the available power supply agrees with the value specified on the rating plate of the respective power supply unit.
- ☞ The power supply unit belonging to the Stemi is a protective class II unit.
- ☞ Internal parts can carry hazardous voltages when a power supply unit is connected to the mains. The power supply unit must therefore be disconnected from the mains before opening it.
- ☞ Make sure that only those fuses are used as spares for the respective power supply unit that are actually intended for the prescribed rated current and the specified version. It is forbidden to use provisional fuses or to short-circuit the fuse holders.

-
- ☞ Modifications to the unit to keep in line with technical progress are always reserved.
-

1 Description

1.1 Designation, purpose

Manufacturer's designation: stereo microscope Stemi 1000
stereo microscope Stemi 2000
stereo microscope Stemi 2000-C
stereo microscope Stemi 2000-CS

Brief designation: Stemi 1000
Stemi 2000
Stemi 2000-C
Stemi 2000-CS

Within the product family of stereo microscopes from Carl Zeiss, these units fit in as follows:

- Greenough type: Stemi D
Stemi DRC
- Telescopic type: Stemi SV 6
Stemi SV 11
Stemi SV 11 Apo

Stemi 1000
Stemi 2000
Stemi 2000-C
Stemi 2000-CS

Stemi 1000 and Stemi 2000 are universally applicable Greenough type stereo microscopes that unite a high imaging quality, compact ergonomic design and internationally standardised connection and coupling points.

While the Stemi 1000 and Stemi 2000 are units for visual stereoscopic observation, with its trinocular tube the Stemi 2000-C offers all possibilities of micrographic and video image documentation.

Unlike the Stemi 2000-C, the Stemi 2000-CS features a fixed camera port with a 50/50 % beam splitting ratio, i. e. the camera port has no switching lever. Unlike the Stemi 2000-C, the Stemi 2000-CS therefore provides the benefit of simultaneous stereoscopic viewing while taking photographs or working in the monitor mode.

Both stereo microscopes' areas of use cover the following focal areas, among other things:

- Materials technology and sciences
- Biotechnology and medical technology
- Semiconductors industry and research
- Hobby and leisure

IMPORTANT The units may only be used for the work and applications described in this manual. Refer also to the product liability declaration (Page VIII).

1.2 Description of the units

The Stemi 1000, Stemi 2000 and Stemi 2000-C are highly powerful stereo microscopes that are distinguished by compact and ergonomic design.

Figure 1-1 shows the principal assemblies of the Stemi 2000-C.

- Stand S with 260 mm column (1-1/4)
- Stemi mount with drive for column 32 (1-1/6)
- Stemi 2000-C microscope body (1-1/2)
- Eyepieces W-PL 10x/23 Spec. foc. (1-1/1) with eye cup
- Built-in 6 V, 10 W halogen vertical illumination (1-1/5) with 115/230 V – 6 V 50 VA power supply (1-1/3)

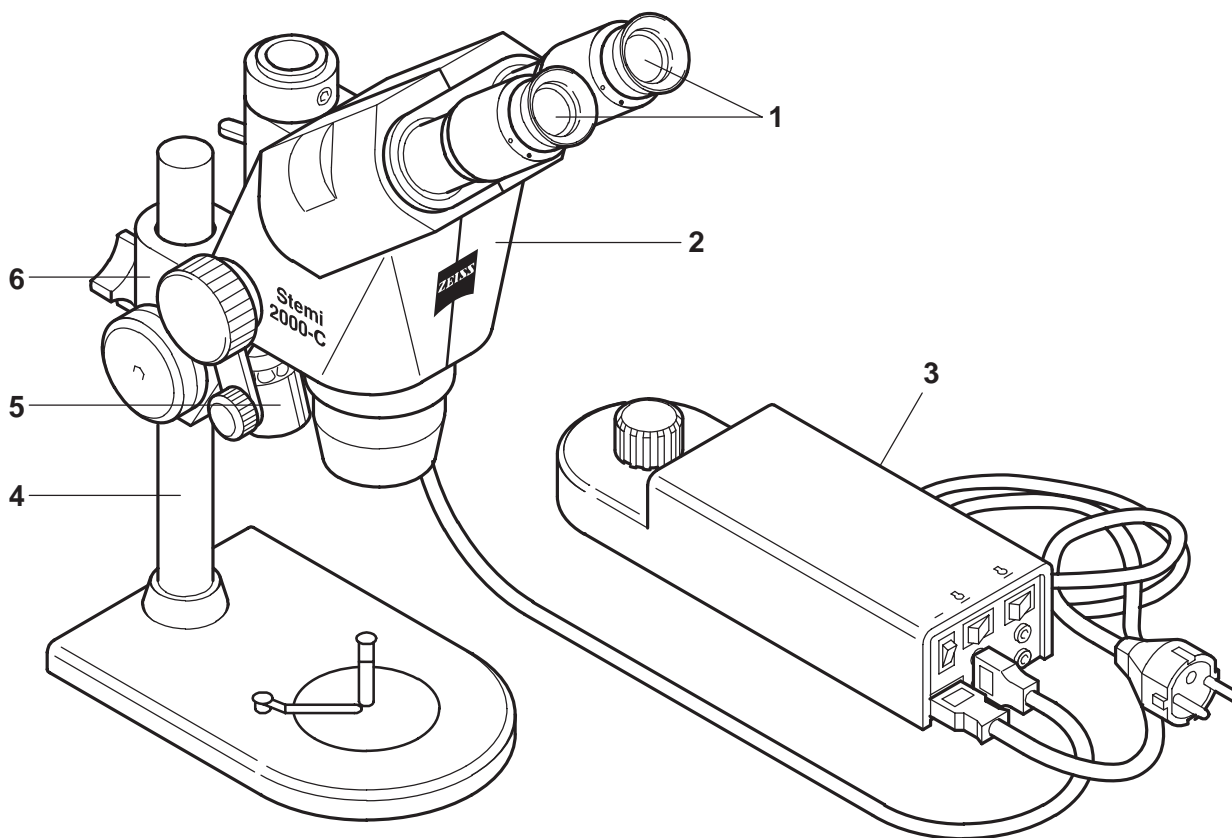

Figure 1-1 Principal assemblies of the Stemi 2000-C

Figure 1-2 schematically shows the optical beam path in the Stemi 2000-C. The unit is switched over between the right tube connector and the camera output with the aid of an adjustable reflector group located under the tube system that features 100/0 % and 0/100 % intensities.

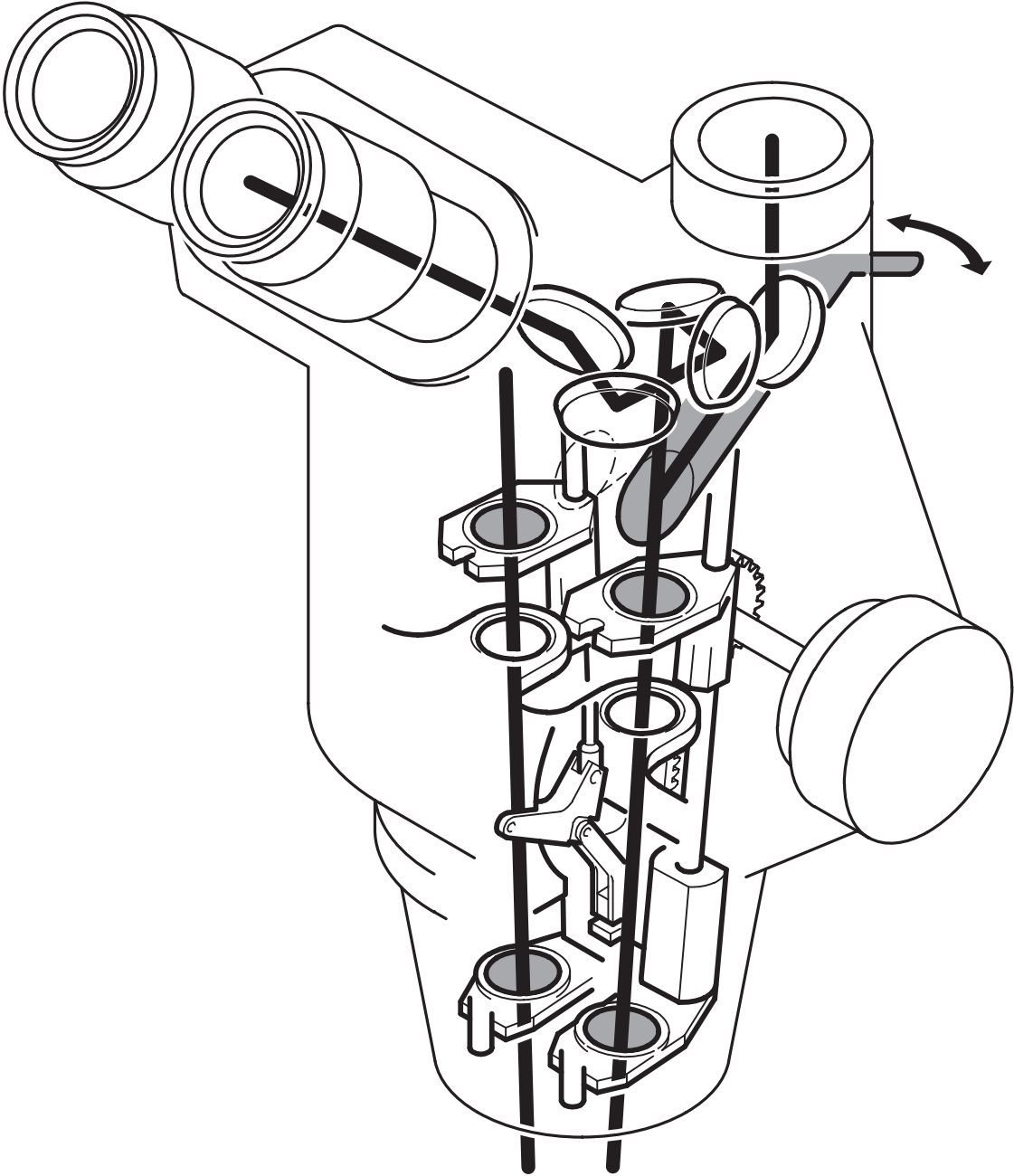

Figure 1-2 Optical schematic of the Stemi 2000-C



1.3 Technical data

(1) Dimensions and weight

Mikroscope

- Stemi 1000
Dimensions (width x depth x height) 65 x 336 x 371 mm
Weight (with power supply, mains cable and lamp) 4.33 kg
- Stemi 2000
Dimensions (width x depth x height) 65 x 336 x 371 mm
Weight (with power supply, mains cable and lamp) 4.53 kg
- Stemi 2000-C
Dimensions (width x depth x height) 65 x 336 x 371 mm
Weight (with power supply, mains cable and lamp) 4.8 kg
- Stand S
Support area (width x depth) 180 x 270 mm
Weight 1.3 kg
- Stand S and power supply unit 230 V - 6 V 50 VA
Support area (width x depth) 263 x 270 mm
Weight 1.96 kg

City Box

Dimensions (closed) (width x depth x height) 560 x 450 x 240 mm
Weight (unequipped) 4.75 kg

(2) Ambient conditions

Storage and transport (in packaging)

Permissible ambient temperature -40 to +70 °C
Permissible relative humidity $\leq 100\%$
Permissible atmospheric pressure 500 to 1060 mbar
Permissible sinusoidal oscillations 10 to 150 Hz; 0.5 g
Permissible impact (handling impact) 30 g; 6 ms



Operation

Permissible ambient temperature	+15 to +35 °C
Permissible relative humidity	≤ 85 %
Permissible atmospheric pressure	800 to 1060 mbar
Permissible impact (handling impact without unit packaging)	10 g; 6 ms; 100 impacts in operating position

(3) Operating data

230 V – 6 V 50 VA power supply (Order No. 458420)

120 V – 6 V 50 VA power supply (Order No. 458421)

Mains voltage	120 V or 230 V
Permissible mains voltage fluctuation	+6/-10 %
Mains frequency	50/60 Hz
Power consumption	max. 50 VA
Light source	halogen 6 V 10 W
Variation range	2.4 ... 5.8 V continuously
Class of protection	II
Electrical degree of protection	IP 20
Electric safety	in acc. IEC 1010-1
RFI suppression	in acc. EN 55011 Class B

Power supply unit, stabilised 6 V 20 W, 115 V – 230 V, variable 1.5 ... 6 V, 50 ... 60 Hz, 40 VA (Order No. 458415)

Mains voltage	100 V, 115 V, 220 V, 240 V, switchable
Permissible mains voltage fluctuation	± 10 %
Mains frequency	50 ... 60 Hz
Power consumption	40 VA
Light source	halogen 6 V 20 W
Variation range	1.5 ... 6.0 V continuously
Class of protection	I
Electrical degree of protection	IP 40
Electric safety	in acc. IEC 1010-1
RFI suppression	in acc. EN 55011 Class B



Specimen stages, adjustment ranges

Sliding stage	± 20 mm, rotatable by 360°
Spherical stage	$\pm 30^\circ$ horizontal tilt angle, rotatable by 360°
Rotary stage	rotatable by 360°
Specimen guide D	28 x 75 mm
Expandable stage with specimen guide and holding frame	76 x 50 mm

Stage inlay plates

Outer diameter	84 mm
Outer diameter (rotary stage)	72 mm

Stemi mount with drive for column 32

Focusing by means of focusing drive	46 mm
Mount for microscope body	\varnothing 76 mm

(4) Optical and mechanical data

Stemi 1000 microscope body

Effective principle	according to GREENOUGH with optical compensation
Stereo angle	11°
Zoom range of the pancratic lens	0.7x ... 3.5x
Free working distance (without dust glass)	112 mm
Viewing angle	35°
Adjustable eye distance	55 to 75 mm
Mount diameter	76 mm

Stemi 2000/2000-C microscope body

Effective principle	according to GREENOUGH with mechanical compensation
Stereo angle	11°
Zoom range of the pancratic lens	0.65x ... 5.0x
Free working distance (without dust glass)	92 mm
Viewing angle	35°

1.4 Overview of modules

Basic microscope equipment

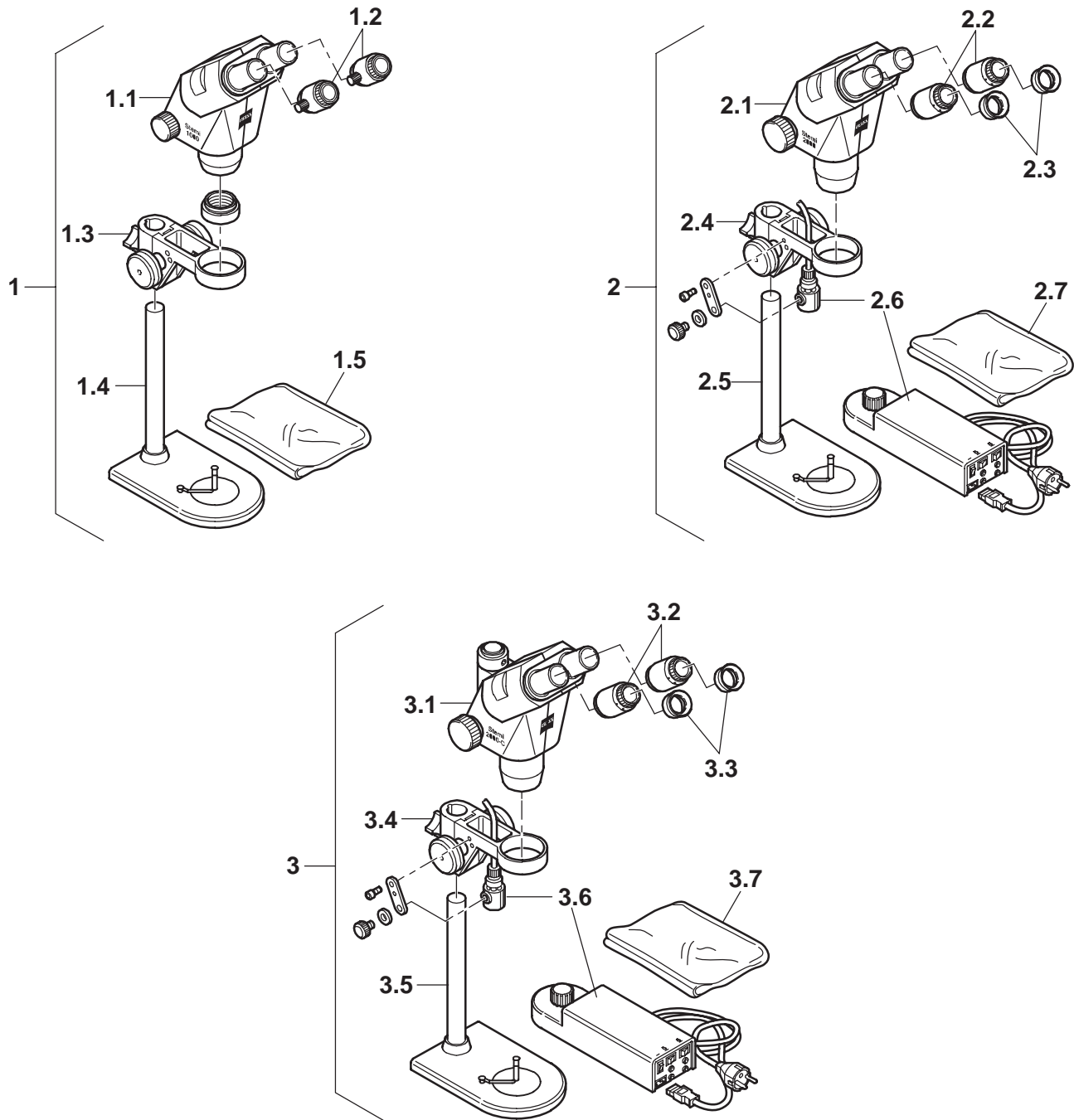

Figure 1-3 Basic microscope equipment

Microscope equipment		Order No.	Stemi 1000	Stemi 2000	Stemi 2000-C
1	Stereo microscope Stemi 1000 consisting of		●		
1.1	● Stemi 1000 microscope body	455050	●		
1.2	● Eyepiece W 10x/21 foc. 2x	455042	●	●	●
-	● Attachment systems adapter (contained in 455050)	-	●		
1.3	● Stemi mount with drive for column 32	455094	●	●	●
1.4	● Stand S, with column 32, 260 mm long	455104	●	●	●
1.5	● Dust cover K	459300	●	●	●
2	Stereo microscope Stemi 2000 with built-in 6 V, 10 W halogen vertical illumination (230 V) consisting of	495102 9804		●	
2.1	● Stemi 2000 microscope body	455052		●	
2.2	● Eyepiece W-PL 10x/23 spectacle focusing 2x	455043	●	●	●
2.3	● Eyepiece cup 2x	444801	●	●	●
2.4	● Stemi mount with drive for column 32	455094	●	●	●
2.5	● Stand S with column 32, 260 mm long	455104	●	●	●
2.6	● Built-in 6 V, 10 W halogen vertical illumination (230 V)	485001 9804		●	●
2.7	● Dust cover K	459300	●	●	●
not illus.	Stereo microscope Stemi 2000 with built-in 6 V, 10 W halogen vertical illumination (120 V)	495102 9904		●	
3	Stereo microscope Stemi 2000-C with built-in 6 V, 10 W halogen vertical illumination (230 V) consisting of	495104 9804			●
3.1	● Stemi 2000-C microscope body	455053			●
3.2	● Eyepiece W-PL 10x/23 spectacle focusing 2x	455043	●	●	●
3.3	● Eyepiece cup 2x	444801	●	●	●
3.4	● Stemi mount with drive for column 32	455094	●	●	●
3.5	● Stand S with column 32, 260 mm long	455104	●	●	●
3.6	● Built-in 6 V, 10 W halogen vertical illumination (230 V)	485001 9804		●	●
3.7	● Dust cover K	459300	●	●	●
not illus.	Stereo microscope Stemi 2000-C with built-in 6 V, 10 W halogen vertical illumination (120 V) but with:	495104 9904			●
	● 120 V – 6 V 50 VA power supply with mains cable and American flat plug	458421		●	●
not illus.	Stereo microscope Stemi 2000-CS with stand N and universal vertical illumination (230 V) (115 V)	000000 1006 130 000000 1006 132			

● Part of the microscope equipment

▲ Unit capable of functioning in conjunction with the microscope equipment

Accessories

(1) Replaceable optical systems

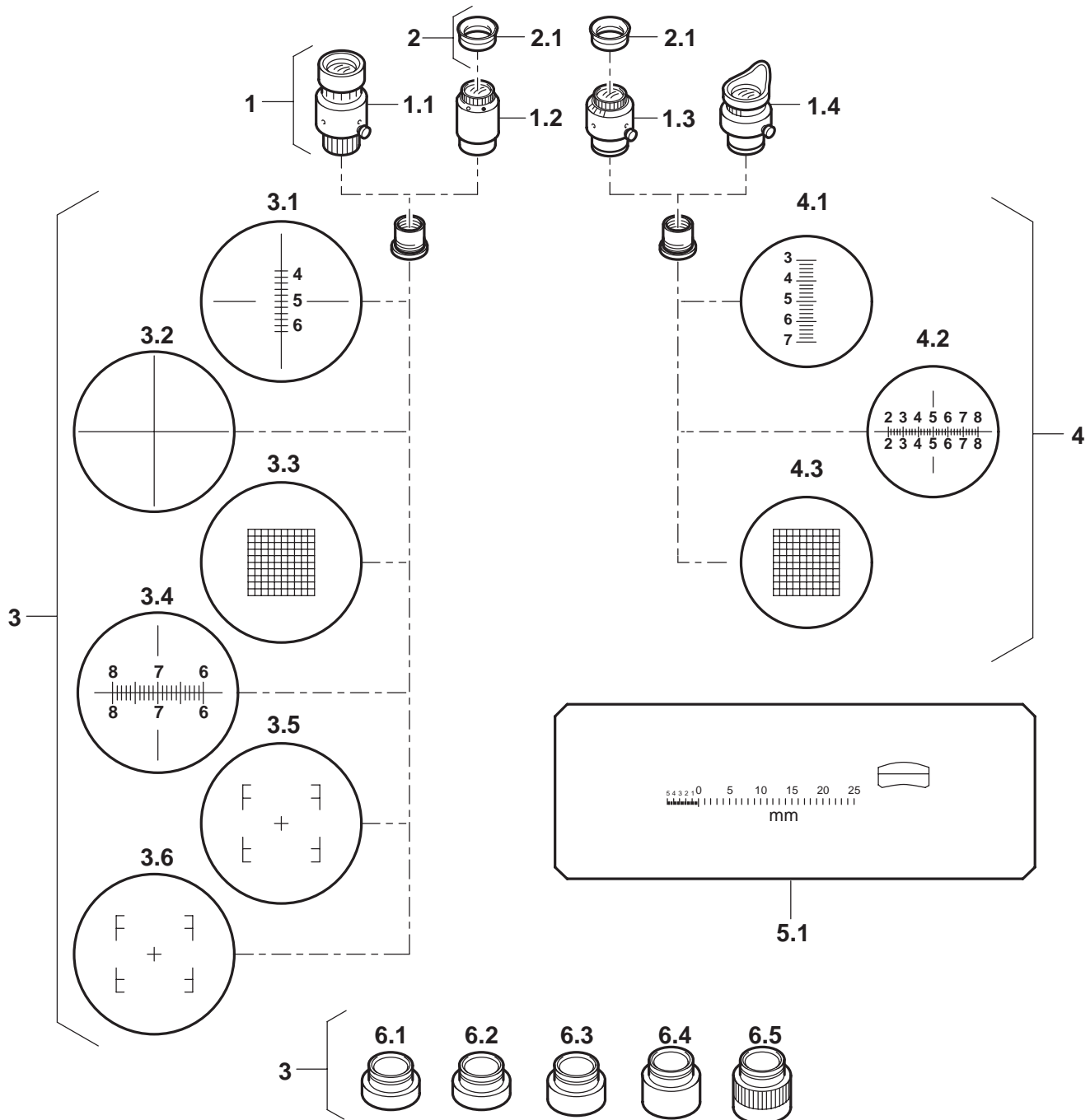

Figure 1-4 Eyepieces/eyepiece cups/reticules/attachment systems/specimen measuring plate

Replaceable optical systems		Order No.	Stemi 1000	Stemi 2000	Stemi 2000-C
1	Eyepieces				
1.1	W 10x/21 foc. with eyepiece cup 2x	455042	▲	▲	▲
1.2	W-PL 10x/23 spectacle focusing 2x	455043	▲	▲	▲
1.3	W-PL 16x/16 spectacle focusing 2x	455048	▲	▲	▲
1.4	W 25x/10 foc. with eyepiece cup 2x	455046	▲	▲	▲
2	Eyepiece cups				
2.1	• Cup for eyepieces 2x each W-PL 10x/23 and W-PL 16x/16	444801	+	+	+
3	Reticules for eyepieces W 10x/21 and W-PL 10x/23				
	• Reticule holder		+	+	+
3.1	• Cross hair micrometer 10:100, Ø 26	474066 9901	+	+	+
3.2	• Eyepiece cross hair reticule, Ø 26	474064	+	+	+
3.3	• Reticulated micrometer 12.5 x 12.5/5; 10 Ø 26	474068	+	+	+
3.4	• Cross hair micrometer 14:140, Ø 26	454060	+	+	+
3.5	• Format reticule MC 10x, Ø 26	454075			+
3.6	• Format reticule MC 12.5x, Ø 26	454076			+
4	Reticules for eyepieces W-PL 16x/16 and W 25x/10				
4.1	• Eyepiece micrometer 10:100, Ø 21	434011	+	+	+
4.2	• Cross hair reticule 10:100, Ø 21	434013	+	+	+
4.3	• Reticulated micrometer 10x10/5: 10, Ø 21	454020	+	+	+
5	Specimen measuring plates				
5.1	• Specimen micrometer 25+50/10 mm (Stemi)	474025	▲	▲	▲
6	Attachment systems				
6.1	• Attachment system 0,3 x	455025	▲	▲	▲
6.2	• Attachment system 0,4 x	455026	▲	▲	▲
6.3	• Attachment system 0,63 x	455027	▲	▲	▲
6.4	• Attachment system 2,0 x	455028	▲	▲	▲
6.5	• Zoom attachment system 0.3 x ... 0.5 x	455029	▲	▲	▲

▲ Unit capable of functioning in conjunction with the microscope equipment

+ Functions in conjunction with further additional equipment

(2) Stands

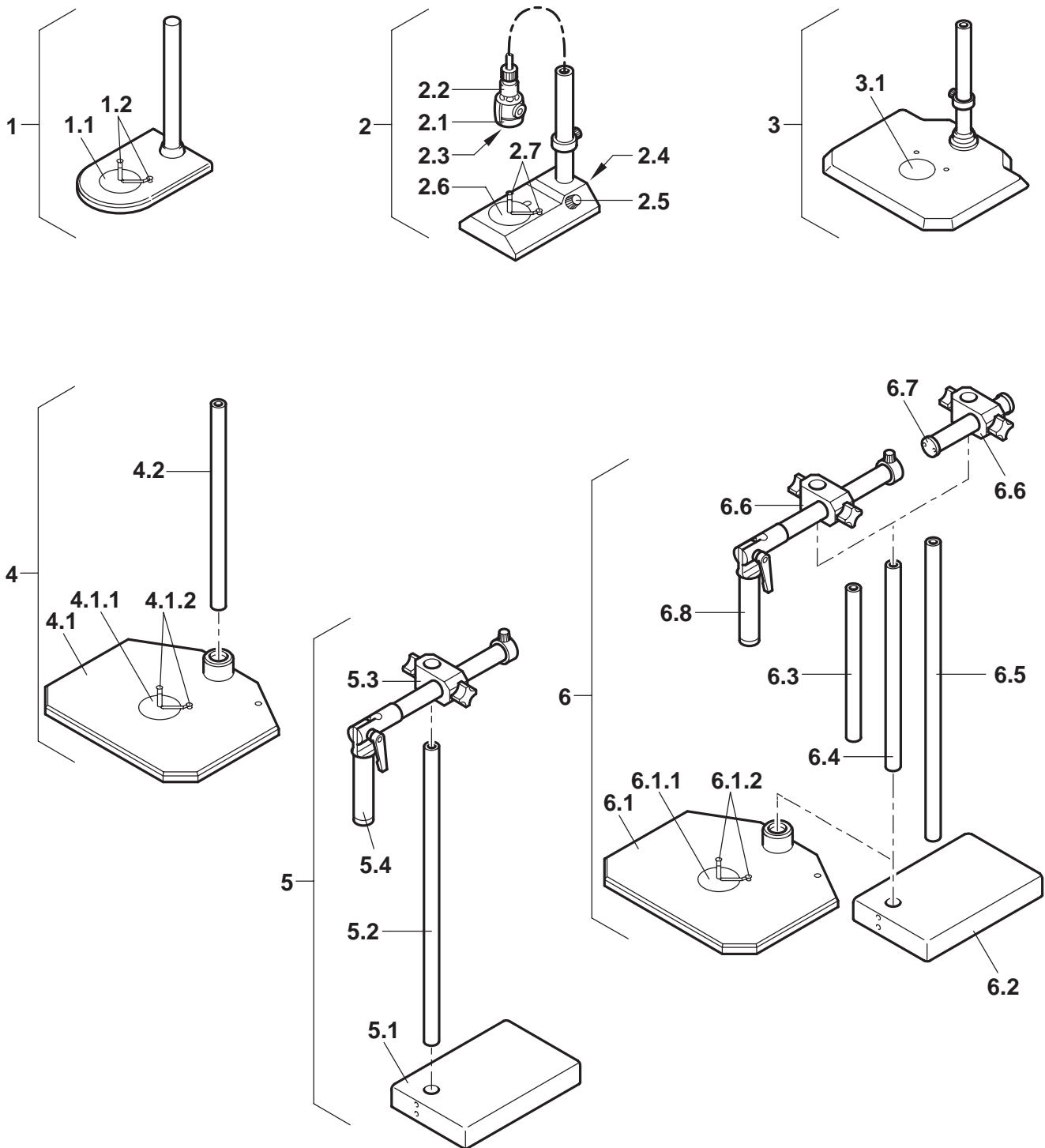

Figure 1-5 Stands

Stands		Order No.	Stemi 1000	Stemi 2000	Stemi 2000-C
1	Stand S, assy. containing:	455104	▲	▲	▲
1.1	• Plastic plate, b/w	475290 9901	+	+	+
1.2	• Stage spring 2x	473371 9902	+	+	+
2	Stand L, assy. (230 V) containing:	455110	▲	▲	▲
2.1	• Lamp 10	467253 9902	+	+	+
2.2	• Lamp socket		+	+	+
2.3	• Halogen lamp 6 V 10 W	386108	+	+	+
2.4	• Built-in transformer				
2.5	• Brightness control		+	+	+
2.6	• Plastic plate, b/w	475290 9901	+	+	+
2.7	• Stage spring 2x	473371 9902	+	+	+
2.8	• Safety-ring	455105 8031	+	+	+
not illus.	Stand L, assy. (120 V)	455108	▲	▲	▲
3	Stand N, assy. containing	455107	▲	▲	▲
3.1	• Plastic plate, b/w	475290 9901	+	+	+
3.2	• Safety-ring	455105 8031	+	+	+
4	Large stand plate with column 32/450 mm, assy. consisting of:		▲	▲	▲
4.1	• Large stand plate 32 (260 x 360 mm) containing:	455101	+	+	+
4.1.1	- Plastic plate, b/w	475290 9901	+	+	+
4.1.2	- Stage spring 2x	473371 9902	+	+	+
4.1.3	- Safety-ring	455105 8031	+	+	+
4.2	• Column 32/450 mm	475120	+	+	+
5	Workplace stand with swivel arm, assy. consisting of:		▲	▲	▲
5.1	• Stage foot 32	455113	+	+	+
5.2	• Column 32/650 mm	475119	+	+	+
5.3	• Cross element 32	455125	+	+	+
5.4	• Tilt head	455117	+	+	+
6	Single components of expandable stands				
6.1	• Large stand plate 32 (260 x 360 mm) containing:	455101	+	+	+
6.1.1	- Plastic plate, b/w	475290 9901	+	+	+
6.1.2	- Stage spring 2x	473371 9902	+	+	+
6.1.3	- Safety-ring	455105 8031	+	+	+
6.2	• Stage foot 32	455113	+	+	+
6.3	• Column 32/350 mm	475123	+	+	+
6.4	• Column 32/450 mm	475120	+	+	+
6.5	• Column 32/650 mm	475119	+	+	+
6.6	Required to connect the columns: • Cross element 32	455125	+	+	+
6.7	Required to hold the Stemi with swivel arm: • Column 32/210 mm with end pieces or	475122	+	+	+
6.8	• Tilt head	475117	+	+	+

▲ Unit capable of functioning in conjunction with the microscope equipment

+ Functions in conjunction with further additional equipment

(3) Specimen stages

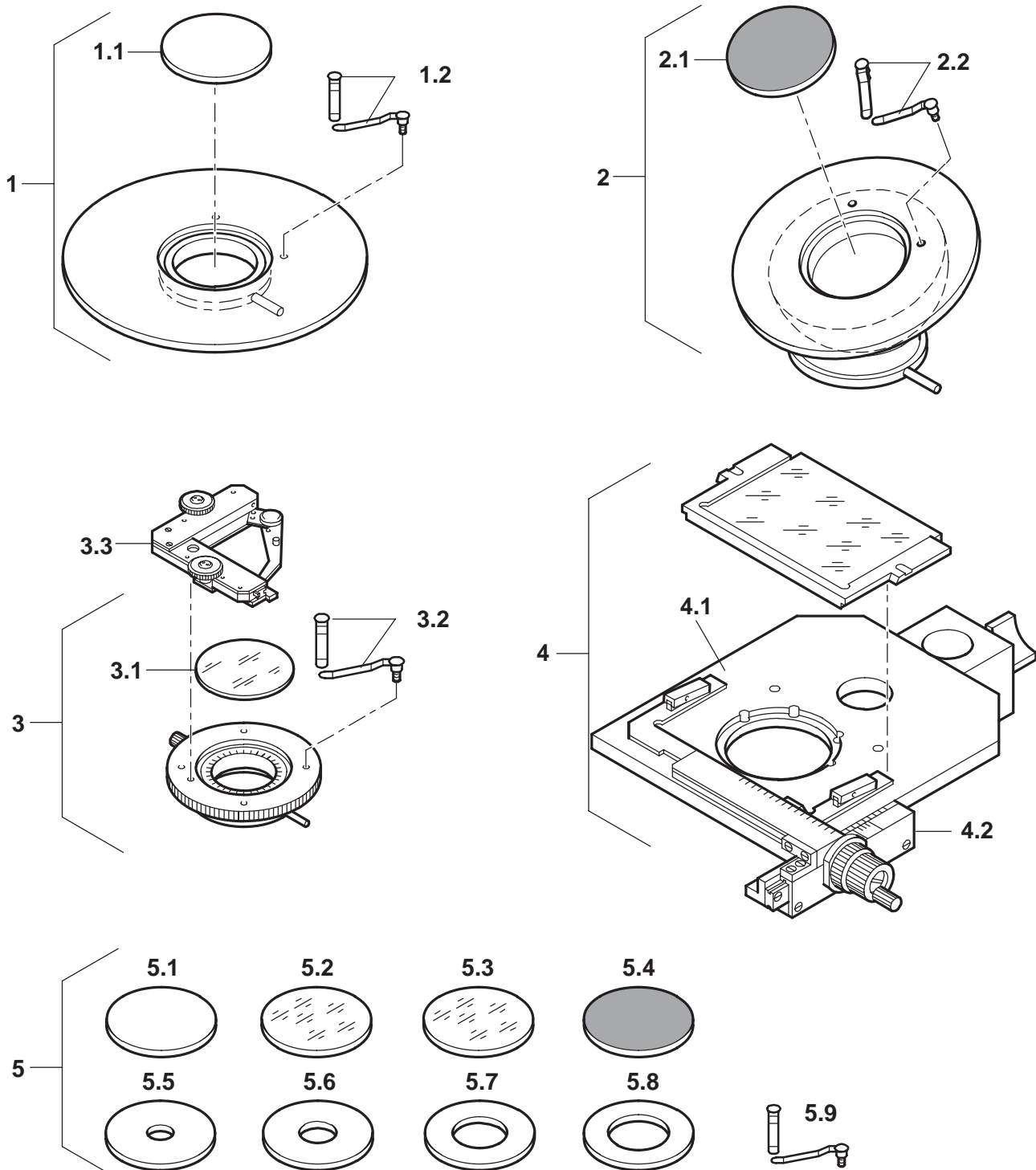

Figure 1-6 Specimen stages

Specimen stages		Order No.	Stemi 1000	Stemi 2000	Stemi 2000-C
1	Sliding stage requiring:	455122	▲	▲	▲
1.1	• Plastic plate, b/w Ø 84	475290 9901	+	+	+
1.2	• Stage spring 2x	473371 9902	+	+	+
2	Ball stage containing	455123	▲	▲	▲
2.1	• Non-slip plate	475288	+	+	+
2.2	• Stage spring 2x	473371 9902	+	+	+
3	Rotary stage for transmitted and vertical illumination containing:	455120	▲	▲	▲
3.1	• Glass plate Ø 72	473378	+	+	+
3.2	• Stage spring 2x	473371 9902	+	+	+
3.3	additionally: • Specimen guide D (28 x 75 mm)	413455	+	+	+
4	Compound table stage for transmitted and vertical illumination, assy. consisting of:		▲	▲	▲
4.1	• Expandable stage with mount 32	413458	+	+	+
4.2	• Specimen guide with holding frame and glass plate (76 x 50 mm shift range)	413458 9001	+	+	+
	Refer to the "Axiovert" price list for details of further holding frames		+	+	+
5	Inlay plates and stage springs				
5.1	• Plastic plate, b/w Ø 84	475290 9901	+	+	+
5.2	• Glass plate, mat coating Ø 84	475291	+	+	+
5.3	• Glass plate, transparent Ø 84	475265 0001	+	+	+
5.4	• Non-slip plate Ø 84	475288	+	+	+
5.5	• Perforated plate Ø 15	475269-110	+	+	+
5.6	• Perforated plate Ø 25	455140-110	+	+	+
5.7	• Perforated plate Ø 40	455140-111	+	+	+
5.8	• Perforated plate Ø 43	475297	+	+	+
5.9	• Stage springs	473371 9902	+	+	+
5.10	• Stage spring 2x	473371 9902	+	+	+

▲ Unit capable of functioning in conjunction with the microscope equipment

+ Functions in conjunction with further additional equipment

(4) Halogen lighting systems for vertical illumination

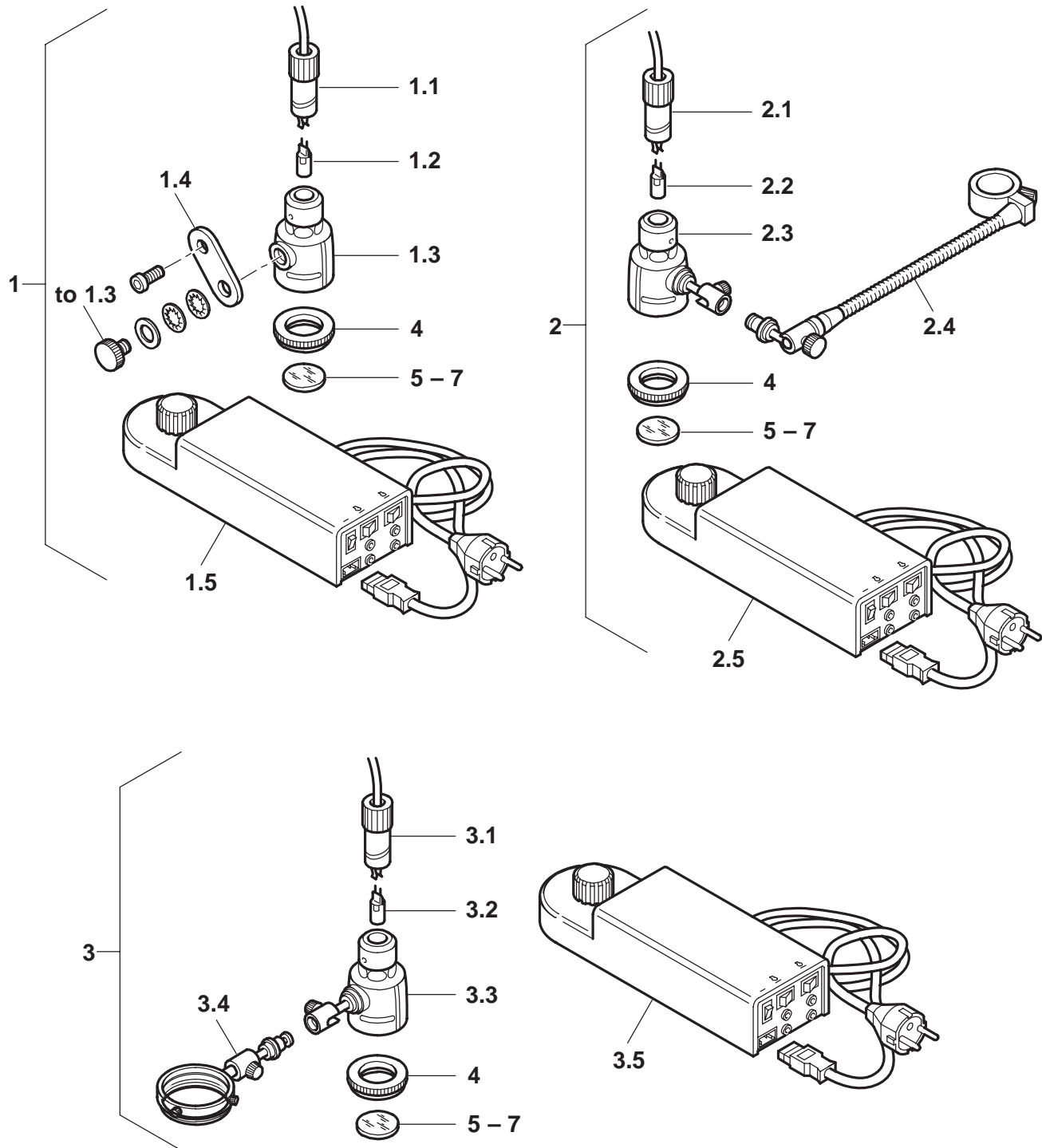

Figure 1-7 Halogen lighting systems for vertical illumination

Halogen lighting systems for vertical illumination		Order No.	Stemi 1000	Stemi 2000	Stemi 2000-C
1	Halogen lighting systems Built-in vertical illumination system 6 V 10 W halogen (230 V) consisting of:	485001 9804	▲	▲	▲
1.1	• HAL 10 W socket for lamp 10	468043 9901	+	+	+
1.2	• Halogen lamp 6 V 10 W	386108	+	+	+
1.3	• Lamp 10	467253 9902	+	+	+
1.4	• Adapter for built-in lamp	455149	+	+	+
1.5	• 230 V – 6 V 50 VA power supply unit with mains cable and Euro-plug	458420	+	+	+
not illus.	Built-in vertical illumination system 6 V 10 W halogen (120 V) consisting of:	485001 9904	▲	▲	▲
	• Parts 1.1 ... 1.4		+	+	+
	• 120 V – 6 V 50 VA power supply unit with mains cable and American flat plug	458421	+	+	+
2	Fit-on vertical illumination system 6 V 10 W halogen (230 V) consisting of:	485002 9804	▲	▲	▲
2.1	• HAL 10 W socket for lamp 10	468043 9901	+	+	+
2.2	• Halogen lamp 6 V 10 W	386108	+	+	+
2.3	• Lamp 10 for lamp mount	455153	+	+	+
2.4	• Lamp mount for column 32	455150	+	+	+
2.5	• 230 V – 6 V 50 VA power supply unit with mains cable and Euro-plug	458420	+	+	+
not illus.	Fit-on vertical illumination system 6 V 10 W halogen (120 V) consisting of:	485002 9904	▲	▲	▲
	• Parts 2.1 ... 2.3		+	+	+
	• 120 V – 6 V 50 VA power supply unit with mains cable and American flat plug	458421	+	+	+
3	Fit-on vertical illumination system 6 V 10 W halogen (230 V) on the front optics consisting of:		▲	▲	▲
3.1	• HAL 10 W socket for lamp 10	468043 9901	+	+	+
3.2	• Halogen lamp 6 V 10 W	386108	+	+	+
3.3	• Lamp 10 for lamp mount	455153	+	+	+
3.4	• Lamp mount for column 32	455151	+	+	+
3.5	• 230 V – 6 V 50 VA power supply unit with mains cable and Euro-plug	458420	+	+	+
	Accessories				
4	• Filter holder Ø 32	466051	+	+	+
5	• Thermal protection filter KG1 Ø 32 x 2	467830	+	+	+
6	• Wide band interference filter, green, Ø 32 x 4	467803	+	+	+
7	• Conversion filter CB12 Ø 32 x 2	467850 9901	+	+	+

▲ Unit capable of functioning in conjunction with the microscope equipment

+ Functions in conjunction with further additional equipment

(5) Cold light sources for vertical illumination

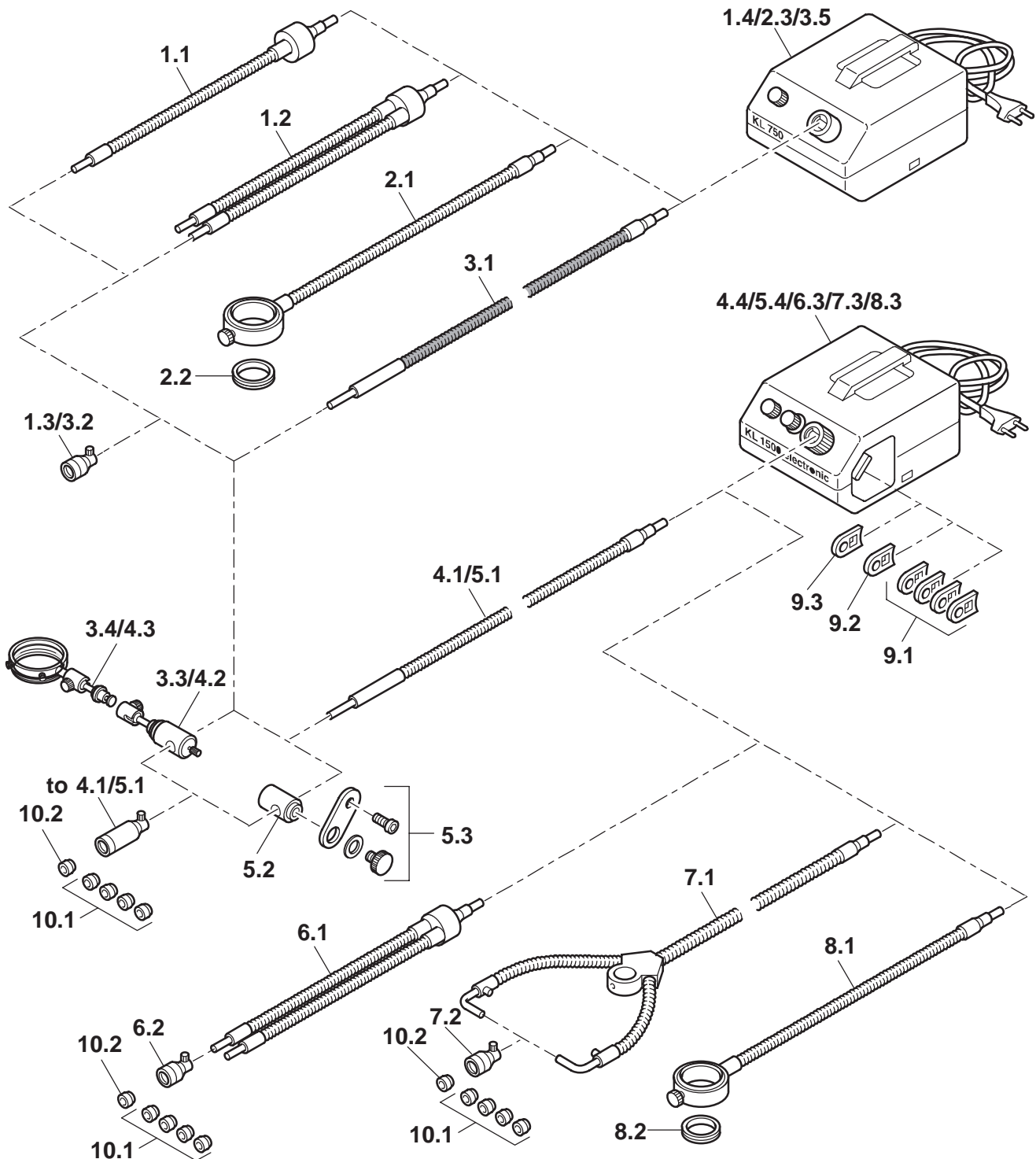

Figure 1-8 Cold light sources for vertical illumination

Cold light sources for vertical illumination (75 W)		Order No.	Stemi 1000	Stemi 2000	Stemi 2000-C
1	Vertical illumination system with swan-neck fibre-optic conductor consisting of:		▲	▲	▲
1.1	• Swan-neck fibre-optic conductor, one-arm, 4.5 mm fibre bundle, 500 mm long for KL 750 (D)	417080 9001	+	+	+
	or				
1.2	• Swan-neck fibre-optic conductor, two-arm, 3.5 mm fibre bundle, 500 mm long for KL 750 (D)	417080 9002	+	+	+
1.3	• Focusing attachment without filter (D) 2x	417059 9901	+	+	+
1.4	• Schott cold light source KL 750 (230 V)	417080	+	+	+
	or				
-	• Schott cold light source KL 750 (120 V)	417081	+	+	+
2	Vertical illumination system with ring lamp consisting of:		▲	▲	▲
2.1	• 6-point ring lamp d = 58 mm (D)	417080 9008	+	+	+
2.2	• Retaining ring for ring lamp	455184	+	+	+
2.3	• Schott cold light source KL 750 (230 V)	417080	+	+	+
	or				
-	• Schott cold light source KL 750 (120 V)	417081	+	+	+
3	Fit-on lighting system with fibre-optic conductor consisting of:				
3.1	• Flexible fibre-optic conductor, one-arm, 4.5 mm fibre bundle, 1000 mm long for KL 750 (D)	417080 9005	+	+	+
3.2	• Focusing attachment without filter (D)	417059 9901	+	+	+
3.3	• Holder for built-in fibre-optic conductor for lamp mount	455143	+	+	+
3.4	• Lamp mount for front optics	455151	+	+	+
3.5	• Schott cold light source KL 750 (230 V)	417080	+	+	+
	or				
-	• Schott cold light source KL 750 electronic (120 V)	417081	+	+	+

Accessories		Order No.	Stemi 1000	Stemi 2000	Stemi 2000-C
9	Inlay filter for Schott cold light source KL 1500 electronic consisting of:				
9.1	• Inlay filter set (D) (blue/red/green/orange filters)	417075 9005	+	+	+
9.2	• Neutralisation filter 0.25 (D)	417075 9006	+	+	+
9.3	• Conversion filter (D)	417075 9007	+	+	+
10	Filter set for focusing attachment				
10.1	• Threaded filter set (D) (blue/red/green/orange filters)	on request	+	+	+
10.2	• Polarisation filter	417065	+	+	+

▲ Unit capable of functioning in conjunction with the microscope equipment

+ Functions in conjunction with further additional equipment

Cold light sources for vertical illumination (150 W)		Order No.	Stemi 1000	Stemi 2000	Stemi 2000-C
4	Fit-on lighting system with fibre-optic conductor consisting of:		▲	▲	▲
4.1	• Flexible fibre-optic conductor with focusing attachment	455145	+	+	+
4.2	• Holder for built-in fibre-optic conductor for lamp mount	455143	+	+	+
4.3	• Lamp mount for front optics	455151	+	+	+
4.4	• Schott cold light source KL 1500 electronic (230 V)	495054 9801	+	+	+
-	or • Schott cold light source KL 1500 electronic (120 V)	495054 9901	+	+	+
5	Built-in lighting system with fibre-optic conductor consisting of:		▲	▲	▲
5.1	• Flexible fibre-optic conductor with focusing attachment	455145	+	+	+
5.2	• Holder for built-in lamp	455144	+	+	+
5.3	• Built-in lamp adapter	455149	+	+	+
5.4	• Schott cold light source KL 1500 electronic (230 V)	495054 9801	+	+	+
-	or • Schott cold light source KL 1500 electronic (120 V)	495054 9901	+	+	+
6	Vertical illumination system with swan-neck fibre-optic conductor consisting of:		▲	▲	▲
-	• Swan-neck fibre-optic conductor, one-arm, 4.5 mm fibre bundle, 750 mm long, self-supporting (D)	417052 9001	+	+	+
-	or				
6.1	• Swan-neck fibre-optic conductor, two-arm, 4.5 mm fibre bundle, 750 mm long, self-supporting (D)	417075 9001	+	+	+
-	or				
-	• Swan-neck fibre-optic conductor, three-arm, 4.5 mm fibre bundle, 750 mm long, self-supporting (D)	417075 9003	+	+	+
6.2	• Focusing attachment without filter (D) 3x	417059 9901	+	+	+
6.3	• Schott cold light source KL 1500 electronic (230 V)	495054 9801	+	+	+
-	or • Schott cold light source KL 1500 electronic (120 V)	495054 9901	+	+	+
7	Universal lighting system for vertical illumination with fibre-optic conductor consisting of:		▲	▲	▲
7.1	• Universal lighting system for vertical illumination with two-arm fibre-optic conductor	455146	+	+	+
7.2	• Focusing attachment without filter (D) 2x	417059 9901	+	+	+
7.3	• Schott cold light source KL 1500 electronic (230 V)	495054 9801	+	+	+
-	or • Schott cold light source KL 1500 electronic (120 V)	495054 9901	+	+	+
8	Lighting system for vertical illumination with split ring lamp consisting of:		▲	▲	▲
8.1	• Split ring lamp (D)	417068	+	+	+
8.2	• Retaining ring for ring lamp	455184	+	+	+
8.3	• Schott cold light source KL 1500 electronic (230 V)	495054 9801	+	+	+
-	or • Schott cold light source KL 1500 electronic (120 V)	495054 9901	+	+	+

(6) Halogen lighting systems for transmitted illumination

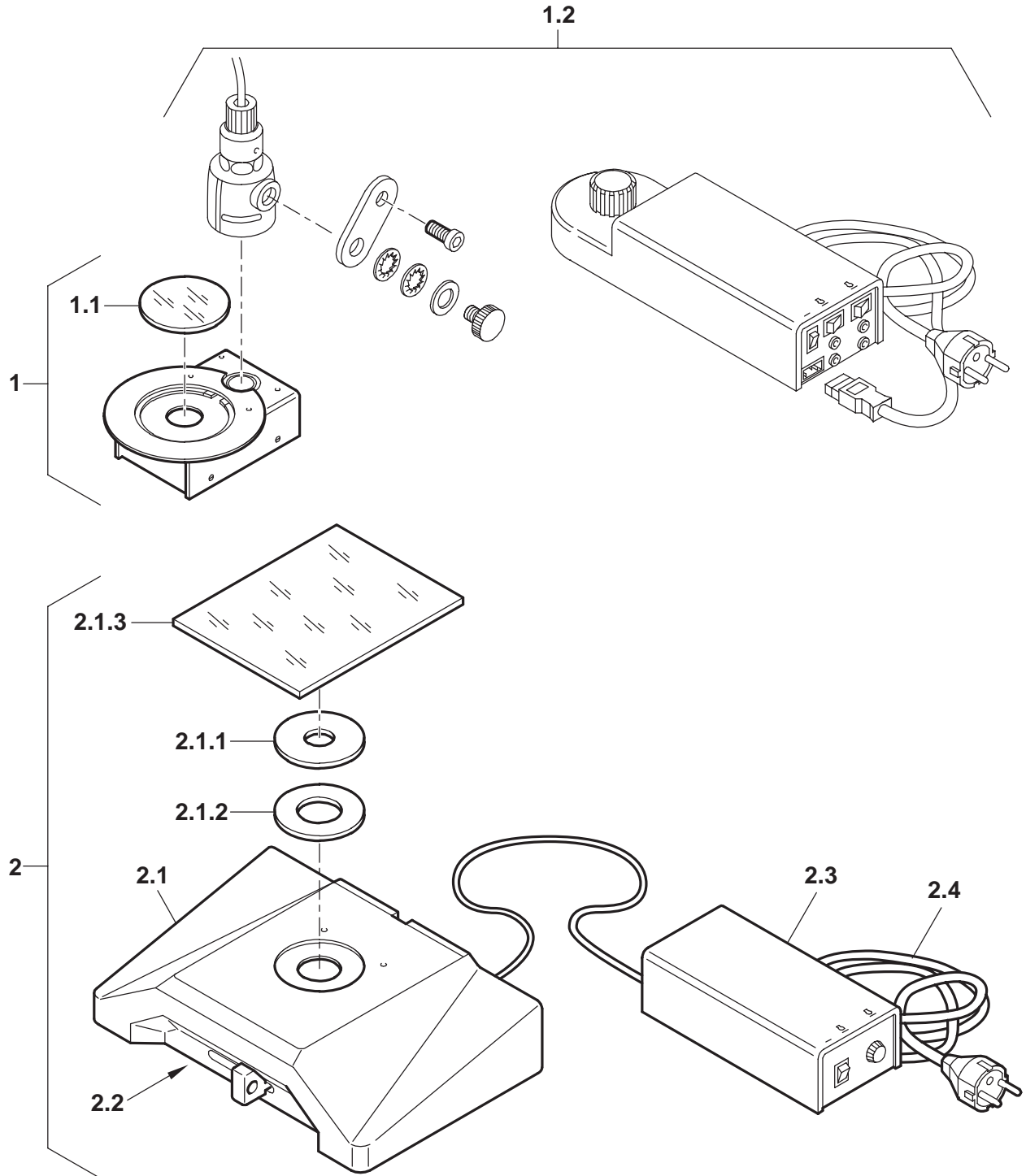

Figure 1-9 Halogen lighting systems for transmitted illumination

Lighting systems for transmitted illumination (halogen)		Order No.	Stemi 1000	Stemi 2000	Stemi 2000-C
1	Option for transmitted illumination with plate Ø 140 containing:	455137	▲	▲	▲
1.1	• Glass plate, transparent Ø 84	475265 0001	+	+	+
Additionally required:					
1.2	• Built-in vertical illumination system 6 V 10 W halogen (230 V)	485001 9804	+	+	+
or					
1.3	• Built-in vertical illumination system 6 V 10 W halogen (120 V)	485001 9904	+	+	+
2	Universal transillumination system (for stand N and stand plate 32) consisting of:	495052 9801	▲	▲	▲
2.1	• Universal transillumination system with swivel reflector with:	455140	+	+	+
2.1.1	– Perforated plate Ø 25				
2.1.2	– Perforated plate Ø 40	455140-111	+	+	+
2.1.3	– Glass plate		+	+	+
2.2	• Halogen lamp 6 V 20 W	2x 380143 1350	+	+	+
2.3	• Power supply unit, stabilised 6 V 20 W (115 V – 230 V)	458415	+	+	+
2.4	• Mains cable with Euro-plug	380138 5810	+	+	+
3	Universal transillumination system (for stand N and stand plate 32) consisting of:	495052 9901	▲	▲	▲
	• Parts 2.1 ... 2.3		+	+	+
not illus.	• Mains cable with American flat plug		+	+	+

▲ Unit capable of functioning in conjunction with the microscope equipment

+ Functions in conjunction with further additional equipment

(7) Cold light sources for transmitted illumination

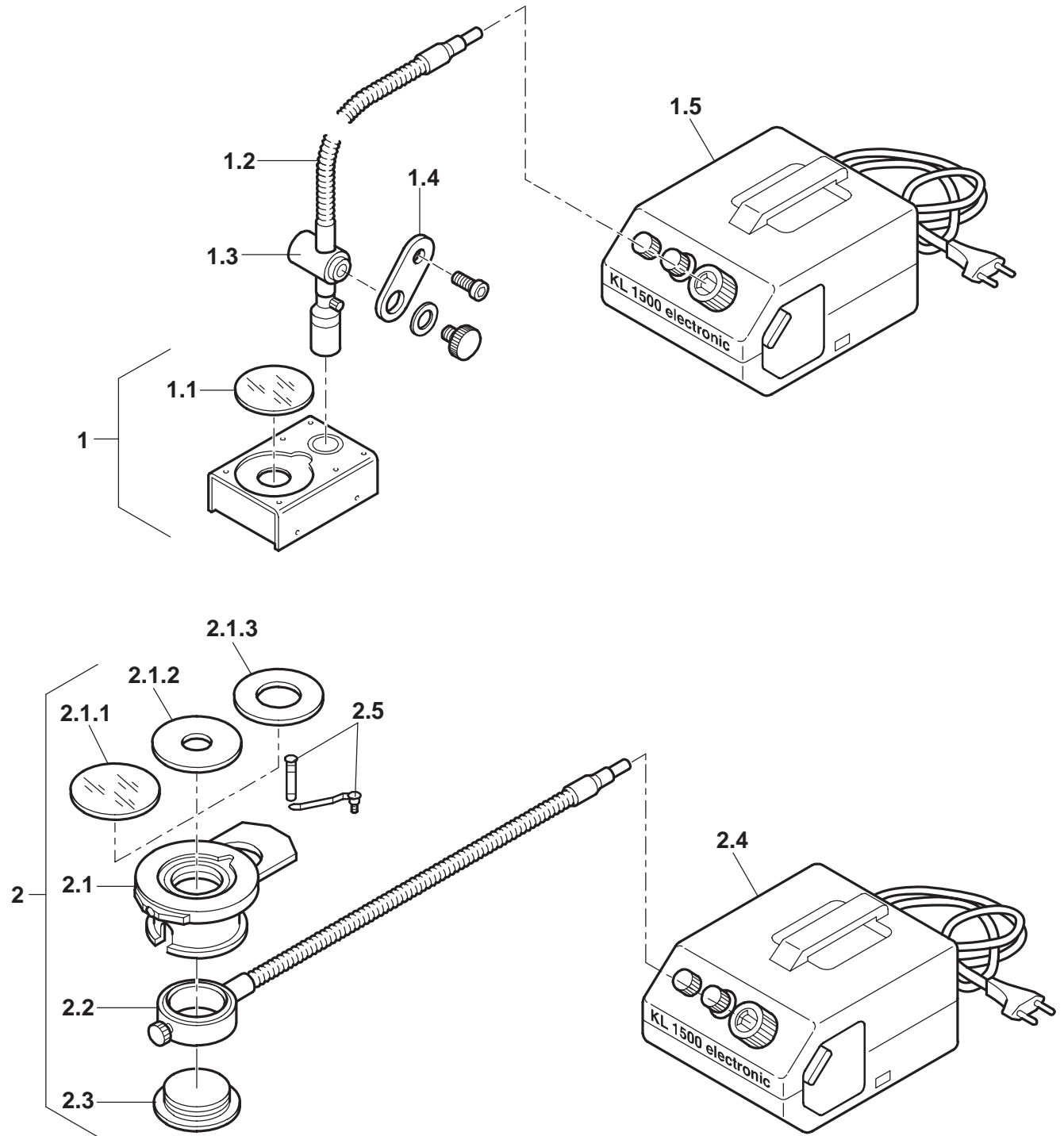

Figure 1-10 Cold light sources for transmitted illumination



Cold light sources for transmitted illumination		Order No.	Stemi 1000	Stemi 2000	Stemi 2000-C
1	Option for transmitted illumination containing:	455136	▲	▲	▲
1.1	• Glass plate, transparent Ø 84	475265 0001	+	+	+
	Additionally required:				
1.3	• Built-in fibre-optic conductor with focusing attachment	455145	+	+	+
1.4	• Holder for fibre-optic conductor	455144	+	+	+
1.5	• Built-in lamp adapter	455149	+	+	+
1.6	• Schott cold light source KL 1500 electronic (230 V)	495054 9801	+	+	+
	or				
1.6	• Schott cold light source KL 1500 electronic (120 V)	495054 9901	+	+	+
2	Transillumination system with fibre-optic conductor for dark field on all sides, switchable to bright field consisting of:	495052 9801	▲	▲	▲
2.1	• Option for bright-dark field transillumination with:	475269	+	+	+
2.1.1	– Glass plate, transparent Ø 84	475265 0001	+	+	+
2.1.2	– Perforated plate Ø 25	455140-110	+	+	+
2.1.3	– Perforated plate Ø 40	455140-111	+	+	+
2.2	• Split ring lamp (D)	417068	+	+	+
2.3	• Transmitted light dark field illumination with specimen support for contact lenses	475278	+	+	+
2.4	• Schott cold light source KL 1500 electronic (230 V)	495054 9801	+	+	+
	or				
2.4	• Schott cold light source KL 1500 electronic (120 V)	495054 9901	+	+	+
2.5	• Stage spring 2x	4733719902	+	+	+

▲ Unit capable of functioning in conjunction with the microscope equipment

+ Functions in conjunction with further additional equipment

(8) Polarisation systems

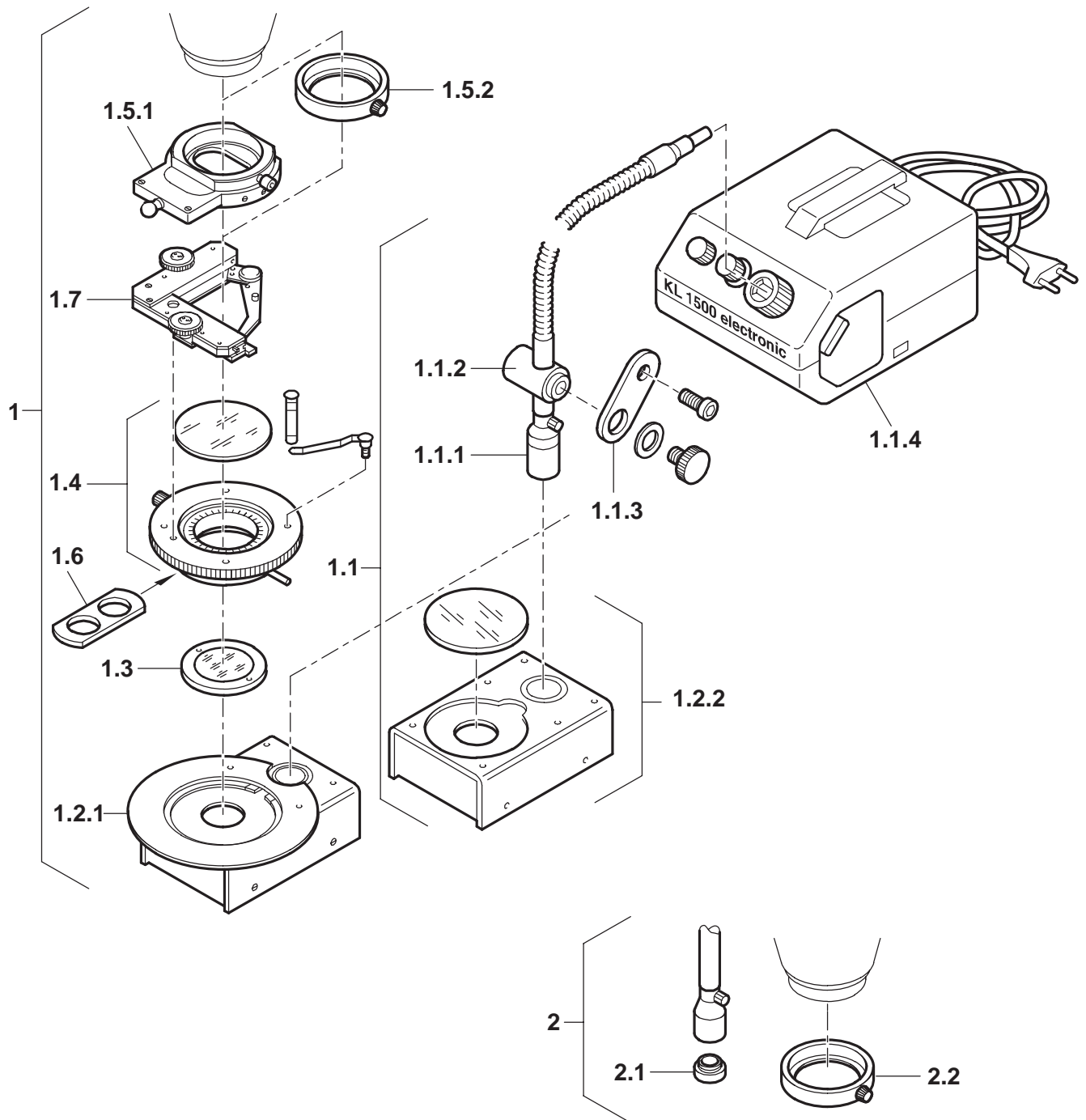

Figure 1-11 Polarisation systems

Polarisation systems		Order No.	Stemi 1000	Stemi 2000	Stemi 2000-C
1	Polarisation contrast in transmitted light consisting of:		▲	▲	▲
1.1	• Built-in vertical illumination system with fibre-optic conductor		+	+	+
1.1.1	– Built-in fibre-optic conductor with focusing attachment	455145	+	+	+
1.1.2	– Holder for built-in fibre-optic conductor	455144	+	+	+
1.1.3	– Built-in lamp adapter	455149	+	+	+
1.1.4	– Schott cold light source KL 1500 electronic (230 V)	495054 9801	+	+	+
	or				
not illus.	– Schott cold light source KL 1500 electronic (120 V)	495054 9901	+	+	+
1.2.1	• Option for transmitted illumination with plate Ø 140	455137	+	+	+
	or				
1.2.2	• Option for transmitted illumination	455136	+	+	+
1.3	• Polariser S	455174	+	+	+
1.4	• Rotary stage for stereo microscopes with stage springs, mount for polariser and glass plate Ø 72	455120 9901	+	+	+
1.5.1	• Analyser slide	455171 9901	+	+	+
1.5.2	• Analyser (A53)	455170	+	+	+
	Accessories				
1.6	• λ slide plate	455172	+	+	+
1.7	• Specimen guide D 28 x 75 mm	413455	+	+	+
2	Additional option for suppressing surface reflections in vertical illumination consisting of:		▲	▲	▲
2.1	• Polarisation filter for focusing attachment (D)	417065	+	+	+
2.2	• Analyser (A53)	455170	+	+	+
	Only applicable in conjunction with the following fibre-optic conductor systems:				
	– Built-in lighting with fibre-optic conductor	(Fig. 1-8/6)			
	– Universal vertical illumination with fibre-optic conductor	(Fig. 1-8/1 or 5)			
	– Universal vertical illumination with swan-neck fibre-optic conductor	(Fig. 1-8/4)			

▲ Unit capable of functioning in conjunction with the microscope equipment

+ Functions in conjunction with further additional equipment

(9) Documentation systems using photo cameras

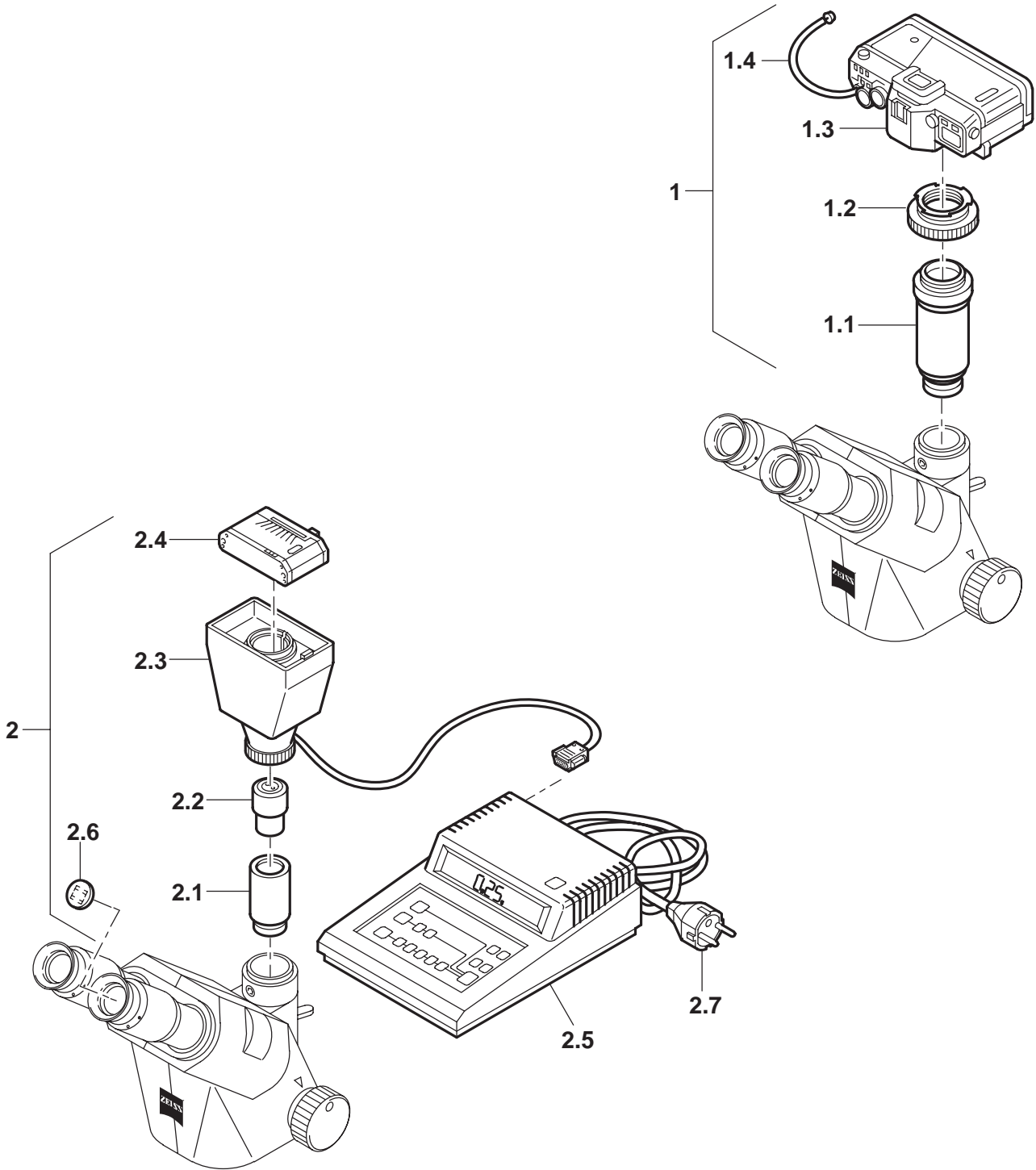

Figure 1-12 Documentation systems using photo cameras



Documentation systems using photo cameras		Order No.	Stemi 1000	Stemi 2000	Stemi 2000-C
1	CONTAX 167 MT reflex camera consisting of:		-	-	▲
1.1	• Reflex camera connection 2.5x for T2	456005			+
1.2	• Special adapter T2 for CONTAX	416010			+
1.3	• Reflex camera housing CONTAX 167 MT	416181			+
1.4	• Cable release	416167			+
	Accessories				
not illus.	• T2 adapter for OLYMPUS OM (OM bayonet)	416002			+
not illus.	• T2 adapter for MINOLTA (SR bayonet)	416003			+
not illus.	• T2 adapter for CANON (FD bayonet)	416004			+
not illus.	• T2 adapter for NIKON F (F bayonet)	416009			+
not illus.	• T2 adapter for PENTAX (KA bayonet)	416011			+
not illus.	• Format reticule MC 10x/Ø 26 if focusing through the viewfinder is not required	454075			+
2	Microscope camera MC 80 DX for 24 x 36 mm consisting of:		-	-	▲
2.1	• Microscope camera connection Ø 30	456006			+
2.2	• Projection lens P 2.5x for MC 80 / MC 80 DX	456021			+
2.3	• Base MC 80 DX	456031			+
2.4	• Film cartridge 35 mm Mot DX	456071			+
2.5	• Control panel MC 80 DX	456048			+
2.6	• Format reticule MC 2,5x/Ø 26	454075			+
2.7	• Mains cable with Euro-plug	380137 6750			+
	or				
not illus.	• Mains cable with American flat plug				+

- ▲ Unit capable of functioning in conjunction with the microscope equipment
- + Functions in conjunction with further additional equipment
- Application not possible

(10) Adapters for video cameras

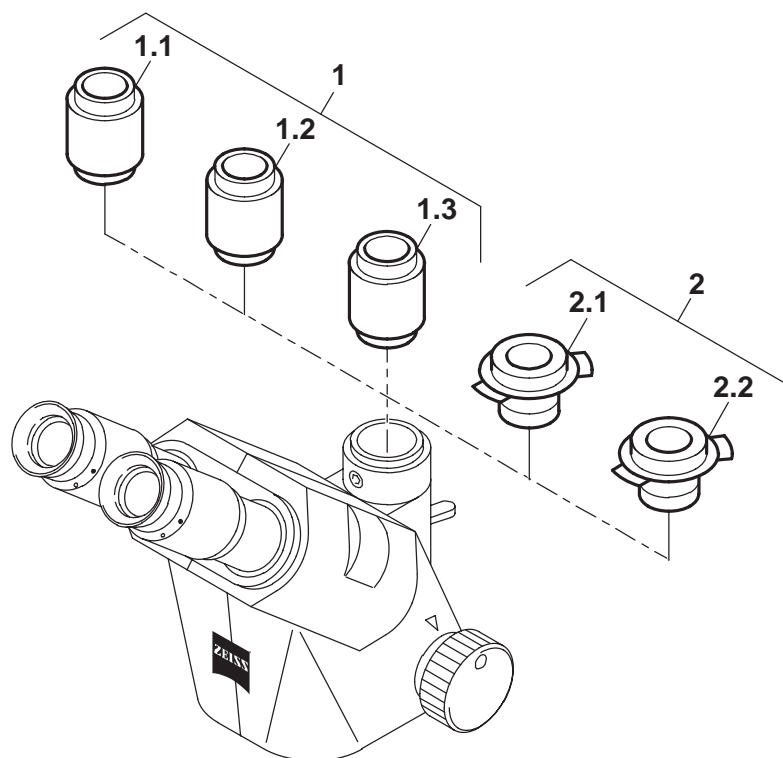

Figure 1-13 Adapters for video cameras

Documentation systems for video cameras		Order No.	Stemi 1000	Stemi 2000	Stemi 2000-C
1	Standard C connection thread				
1.1	• TV camera 2/3" standard C connection (factor 1x)	456105	-	-	+
1.2	• TV camera 1/2" standard C connection (factor 0.5x)	456106	-	-	+
1.3	• TV camera 2/3" standard C connection (factor 0.63x)	456107	-	-	+
2	ENG bayonet connection				
2.1	• TV camera 2/3" ENG mount connection (factor 1x)	456115	-	-	+
2.2	• TV camera 2/3" ENG mount connection (factor 0.8x)	456117	-	-	+
Video cameras and periphery device on request					

- + Functions in conjunction with further additional equipment
- Application not possible

1.5 Function elements

Item No.	Designation	Purpose/description
1	Beam changeover switch (Stemi 2000-C only)	Enables switchover from the right beam to the camera output
2	Camera output (Stemi 2000-C only)	Enables connection of photographic or video cameras
3	Clamping screw (Stemi 2000-C only)	For clamping the camera adapter
4	Binocular tube	Accommodates the two eyepieces; adjustable to the user's eye distance
5	Eyepiece	Enables eye error correction Every marking in the \pm range: 1 diopter
6	Hexagon socket screw	Optional adjustment of continuous zooming and click stop
7	Clamping screw	Fixes the body of the microscope in the Stemi mount
8	Adjustment control	Alters the lamp voltage (brightness)
9	Power switch	Switches the power supply on/off (0 visible: Off)
10	Lamp switch (2x)	Switches the lamp connected the affiliated lamp connector On/Off (red bar visible: On)
11	Mains cable	Mains connection: 230 V - Euro-plug, 120 V - American flat plug
12	Lamp connector, 2-pol (2x)	Connection for lamp
13	Plastic plate b/w	Specimen support (detachable)
14	Stage spring (2x)	Fixes the specimen
15	Dust glass	Prevents dust ingress and serves as a mount for a ring lamp and analysers; when using attachment systems with the Stemi 1000, it must be replaced by the so-called "attachment system adapter"
16	Lamp	Illuminates the specimen
17	Built-in lamp adapter	Secures the lamp on the Stemi mount
18	Securing ring	Secures the Stemi mount

Item No.	Designation	Purpose/description
19	Focusing drive	Enables adjustment of the optical system to the specimen Max. adjustment range: 46 mm The left/right focusing drives are coupled mechanically; their ease of movement can be adjusted by means of the hexagon socket screw
20	Zoom adjustment	Enables continuous adjustment of the zoom range
21	Locking screw	Fixes the Stemi mount at working height

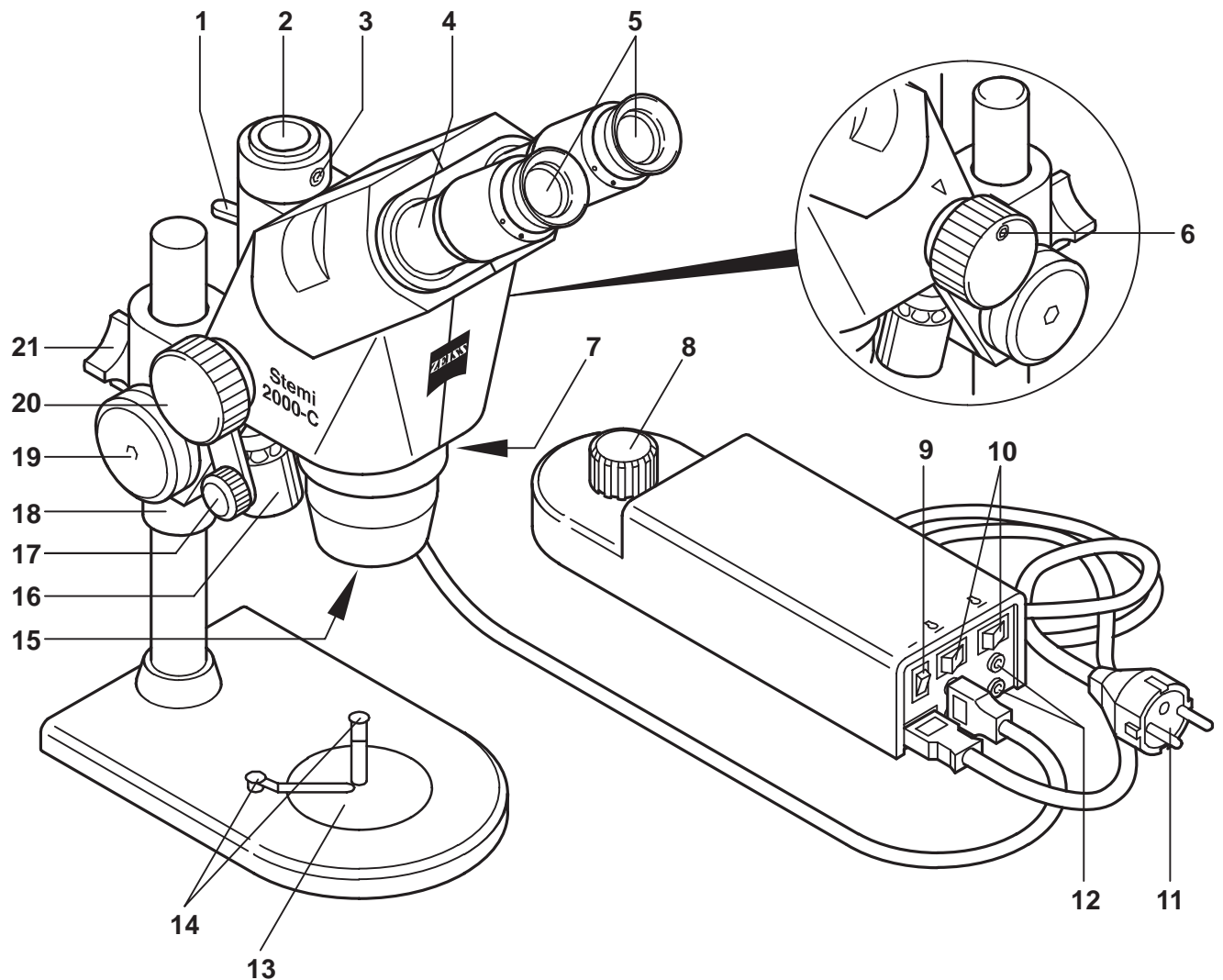

Figure 1-14 Function elements of the Stemi 2000-C



Stemi 1000, Stemi 2000, Stemi 2000-C

2 Operation

2.1 Unpacking and setting up

The components belonging to the microscope are optionally supplied in transport containers or in a city box.

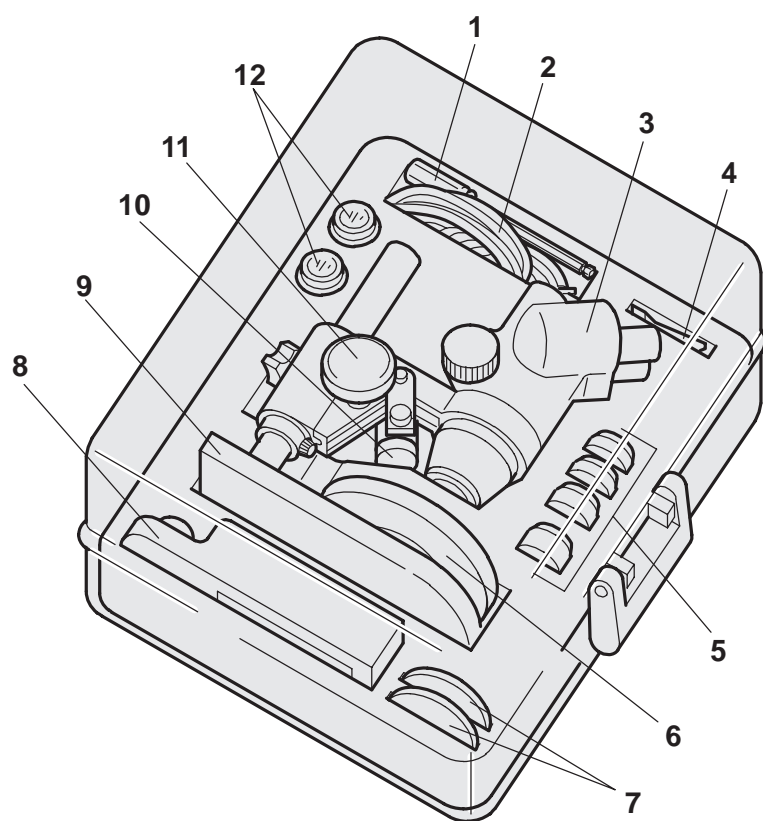

- | | |
|---------------------------------|---------------------------|
| 1 3 mm hexagon socket screw key | 7 Stage inlay plates (2x) |
| 2 Cable | 8 Power supply |
| 3 Microscope body | 9 Stand S |
| 4 Stage springs (2x) | 10 Lamp 10 |
| 5 Attachment systems | 11 Stemi drive |
| 6 Sliding stage | 12 Eyepieces |

Figure 2-1 Stemi 2000-C packing unit in city box

NOTE Components depend on the equipment of the microscope.
Accessories are supplied in commercially available packaging.

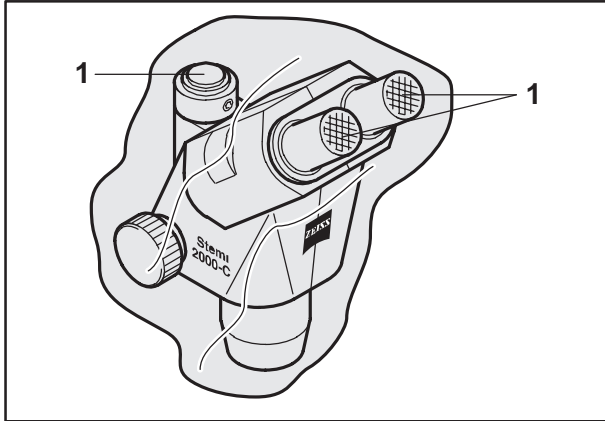

Figure 2-2 Unpacking

(1) Preparations

- Remove the transport sleeve from the body of the microscope.
- Remove the dust caps (2-2/1) from the tube openings.

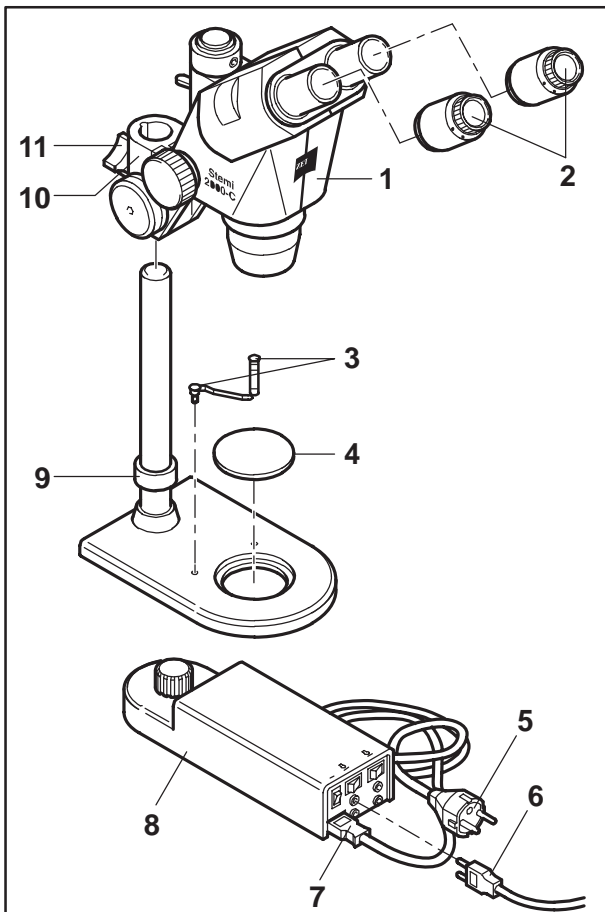

Figure 2-3 Setting up the Stemi 2000-C

(2) Setting up the stereo microscope

- Place the microscope (2-3/1) on your workbench.
- With the locking screw (2-3/11), fix the Stemi mount (2-3/10) at working height.
- If necessary, secure the Stemi mount with the securing ring (2-3/9).
- Insert the b/w plastic plate (2-3/4) in the mount and insert stage springs (2-3/3).
- Insert the eyepieces (2-3/2) in the tube connection. Turn the eyepieces until their reticules are oriented.
- Place the power supply (2-3/8) next to the stand S. Insert the plug of the lamp cable (2-3/6) in the required lamp connection.

IMPORTANT The unit's voltage must correspond to the mains voltage.

- Connect the mains cable (2-3/7) to the power supply. Plug in the mains plug (2-3/5).

2.2 Commissioning

Carry out the following work when commissioning for the first time.

- Unpack and set up the unit as described in Section 2.1 .
- The following adjustments have to be carried out before commissioning or as required.

(1) Adjusting the Stemi 2000 (applies to 1000/2000/2000-C)

- Adapt the binocular tube (2-4/7) to the user's eye spacing.
- Adjust the "0" mark on the eyepieces (2-4/1).
without reticule: to the white point (2-4/2)
with reticule: to the red point (2-4/3).
- Place a specimen in position and illuminate it if necessary.
- With the zoom adjuster (2-4/5), adjust the maximum magnification and focus on the specimen with the focusing drive (2-4/6).
- With the zoom adjuster (2-4/5), adjust the minimum magnification and, if necessary adjust the focus with the respective eyepiece (eye error correction).
- After adjustment, identical specimen details remain focused over the complete zoom range.

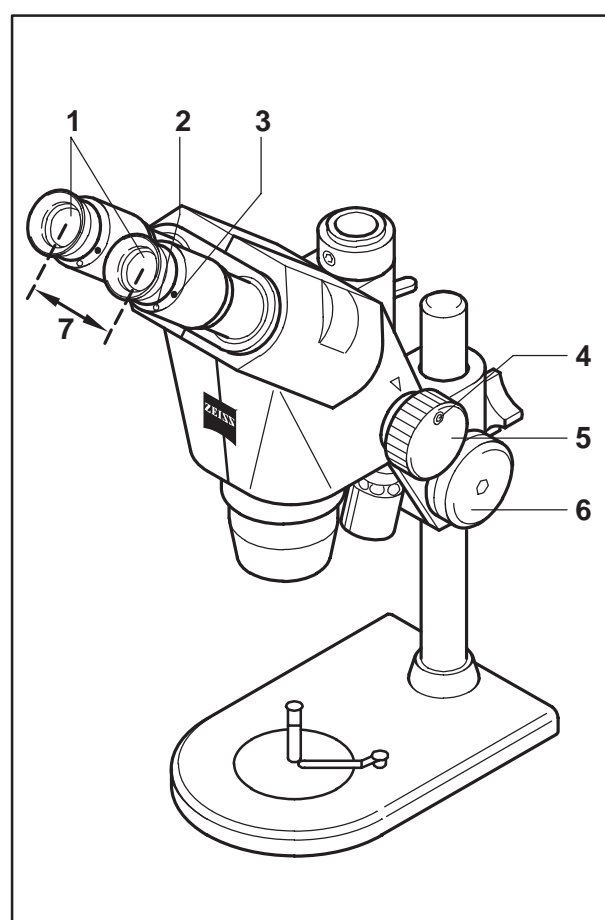

Figure 2-4 Adjusting the Stemi 2000-C

(2) Zoom adjustment

Continuous zooming or **click stop zooming** is possible with the Stemi. To do this, turn the 3 mm hexagon socket screw (2-4/4) slightly to the left or right to switch over from Continuous to Click Stop (and vice versa).

(3) Focusing the Stemi 2000

Assuming the Stemi 2000 is adjusted (Section 2.2 (1)), when focusing to different specimen levels the user merely has to readjust the Stemi mount by means of the focusing drive (if possible, with the maximum zoom factor).

2.2.1 Working with accessories

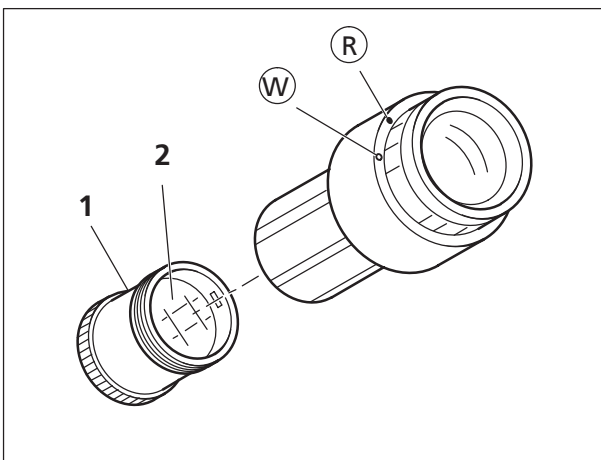

Figure 2-5 Inserting a graticule

(1) Graticules

- Eyepieces of type W-PI 10/23 Br. foc. are designed to allow the use of graticules.
- To compensate the image displacement caused by the extra glass path through the graticule, use the red dot (R) on the diopter scale as zero index instead of the white one (W).
- The graticules (2-5/2) come cemented in mounts with external screw threads (2-5/1) for easy exchange.
- To change a mounted graticule, unscrew the mount (2-5/1) and screw in the desired one instead.
- Check the focus and readjust it if necessary (Section 2.2 (1)).

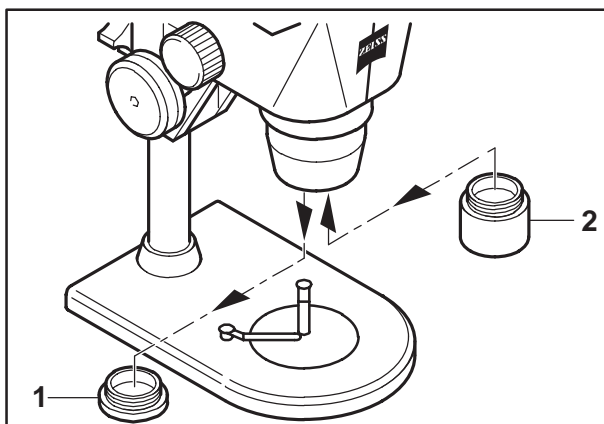

Figure 2-6 Fitting an attachment system to the Stemi 2000

(2) Attachment systems

- Unscrew the dust glass (2-6/1).
- Screw in the required attachment system (2-6/2).

IMPORTANT The free operating distance changes when using an attachment system. Pay attention to the table in Section 1.3(4).

NOTE In the case of the Stemi 1000, in the "attachment systems adapter" supplied, instead of the dust glass. Then screw the required attachment system onto it.

(3) Polarisation contrast in transmitted light

- Insert the polariser (2-7/7) in the rotary stage (2-7/9) from below so that the dot marking on the polariser agrees with the line marking on the stage mount and secure it with two 2.0 mm hexagon socket screws (2-7/4).
- Take the glass plate \varnothing 84 out of the option for transmitted light illumination (2-7/5). Insert the rotary stage in the mount (2-7/6) so that the dot markings of the polariser agree in the x direction.
- Fix the rotary stage with the eccentric clamp (2-7/3).
- Fit the glass plate \varnothing 72 (2-7/10).
- Secure the specimen guide (2-7/11) with the 2.5 mm hexagon socket screw (2-7/12) or insert stage springs (2-7/2).
- Secure the analyser slide (2-7/14) on the dust glass (2-7/1) or on the attachment system.
- Slide in the slide (2-7/13) completely and adjust the graspball to y-direction.
- Slide in the λ -plate slide (2-7/8) with free passage in the beam path.
- In this position, the analyser and polariser are aligned to each other at 90° (dark setting).
- Fine orientation of the dark setting is possible by undoing the eccentric clamp (2-7/3) and by turning the rotary stage slightly.
- The polarisation-optical "Red I" function setting can be selected by sliding in the λ -plate slide (2-7/8).

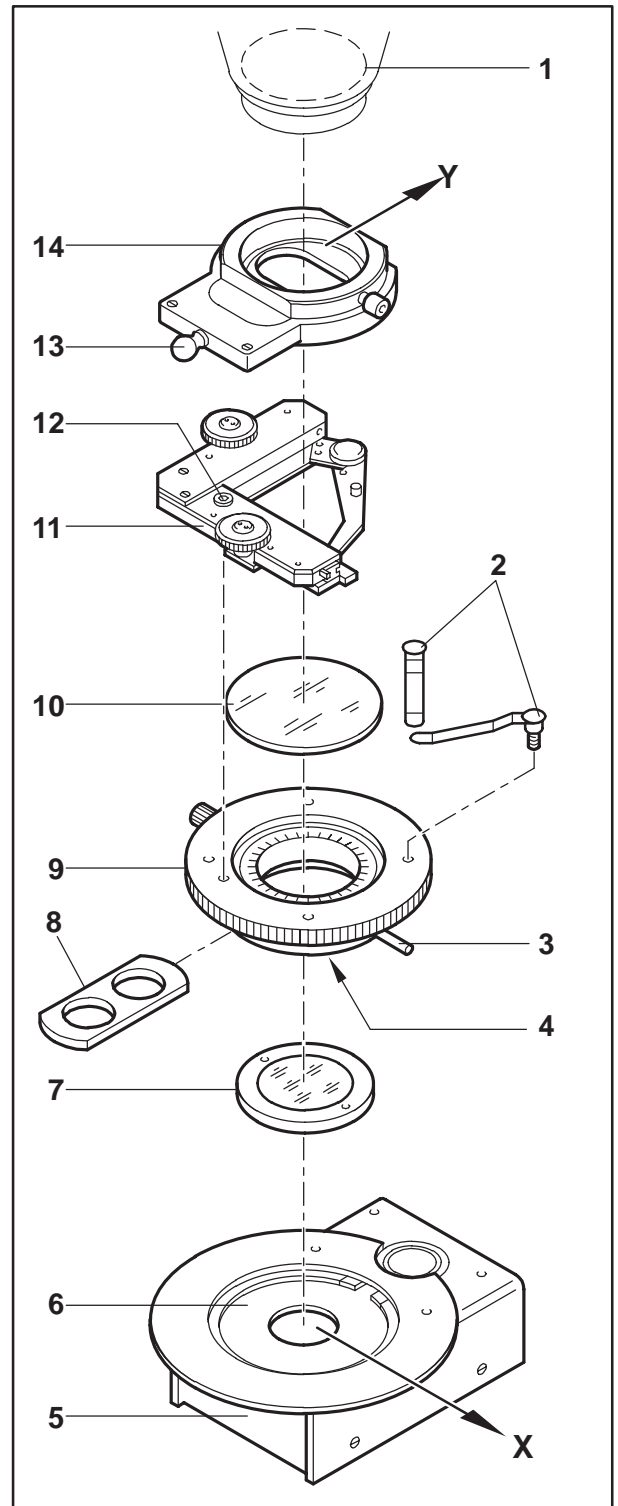

Figure 2-7 Mounting the polariser

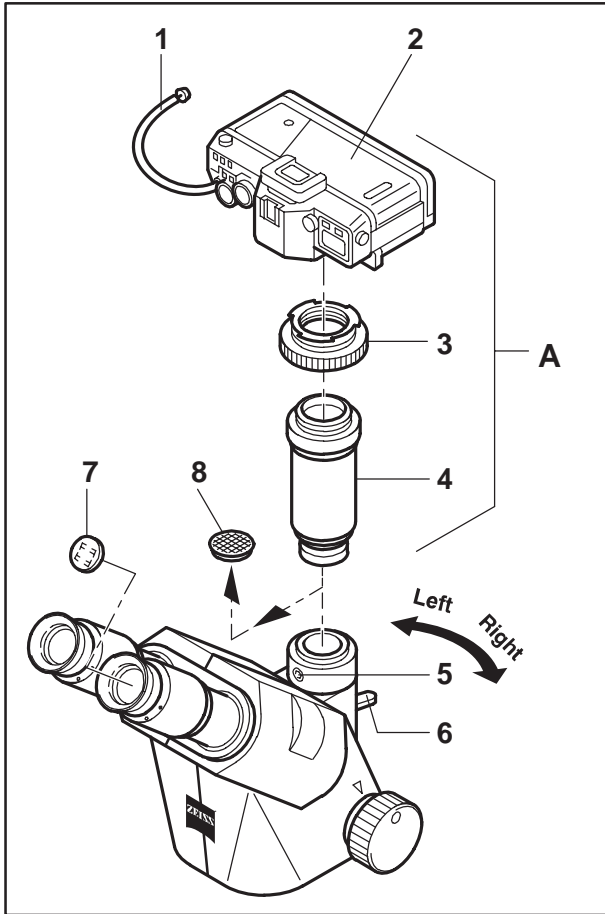

Figure 2-8 Mounting a reflex camera

(4) 35 mm photography with a reflex camera (e.g. CONTAX 167 MT)

- Select the suitable T2 adapter (2-8/3) for the camera system used and screw it onto the connection for a reflex camera 2.5x for T2 (2-8/4).
- Fit the camera (2-8/2) and, if necessary, attach the release (2-8/1).
- Insert the format reticule (2-8/7) if it is not intended to focus via the camera's viewfinder (Section 2.2.1 (1)).
- Detach the dust cap (2-8/8) from the camera tube and insert the pre-assembled unit A in the camera tube.
- Align the unit in the required position and secure it with the hexagon socket screw (2-8/5).
- Adjust the required method of viewing the specimen by means of the changeover switch (2-8/6).

Right: camera not connected

Left: camera connected.

NOTE

Refer to operating manual G 42-406/II "35 mm reflex cameras for microscopes and stereo microscopes" for detailed information on reflex cameras.

(5) 35 mm photography with microscope camera MC 80 DX

- Detach the dust cap (2-9/6) and insert the \varnothing 30 microscope camera connection (2-9/5) in the camera tube and secure it with the hexagon socket screw (3 mm) (2-9/7).
- Screw on the projecting lens P2.5x (2-9/4).
- Fit on the base (2-9/2) until it bottoms and fix it with the knurled screw (2-9/3).
- Insert film.
- Insert the film cartridge (2-9/1) (the EJECT knob springs out). To remove it, press EJECT.
- Connect the connecting cable (2-9/2) to the exposure control (2-9/10).

IMPORTANT The voltage of the exposure control must agree with the mains voltage.

- Plug in the mains plug (2-9/11).
- Use the format reticule (2-9/8) for focusing (Section 2.2.1 (1)).
- Adjust the required method of viewing the specimen by means of the changeover switch (2-9/9):
 Right: camera not connected
 Left: camera connected.

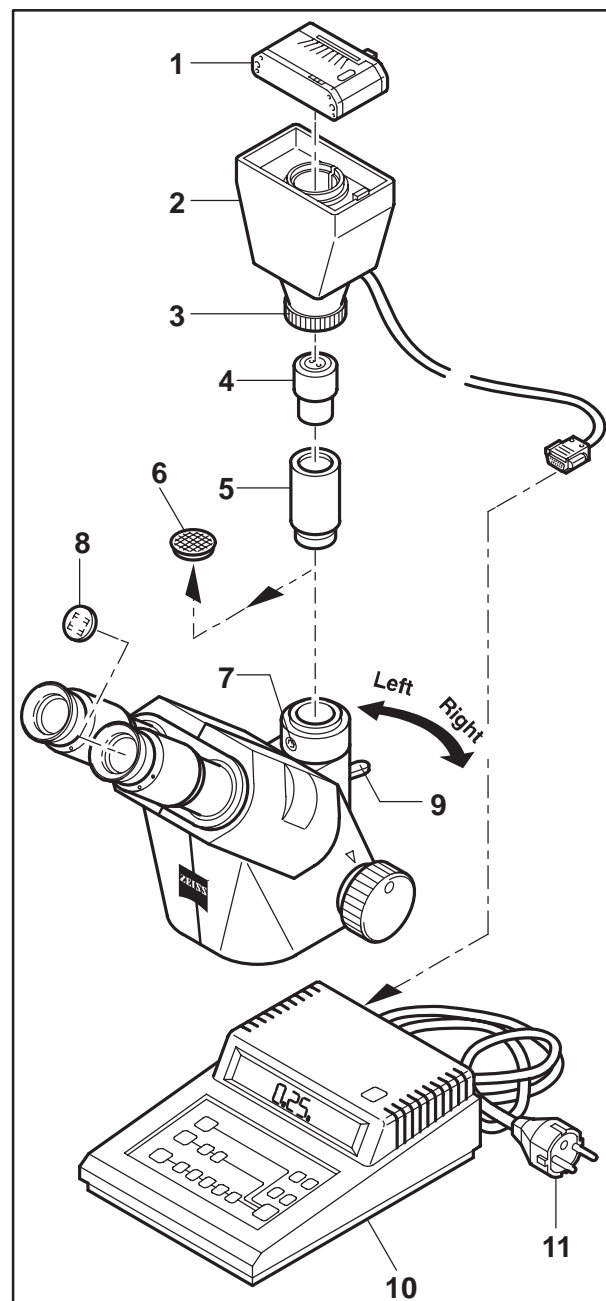

Figure 2-9 Mounting the microscope camera MC 80 DX for 35 mm photography

NOTE Refer to the operating manual G 42-407/1 "Microscope camera MC 80 DX" for detailed information on the microscope camera MC 80 DX.

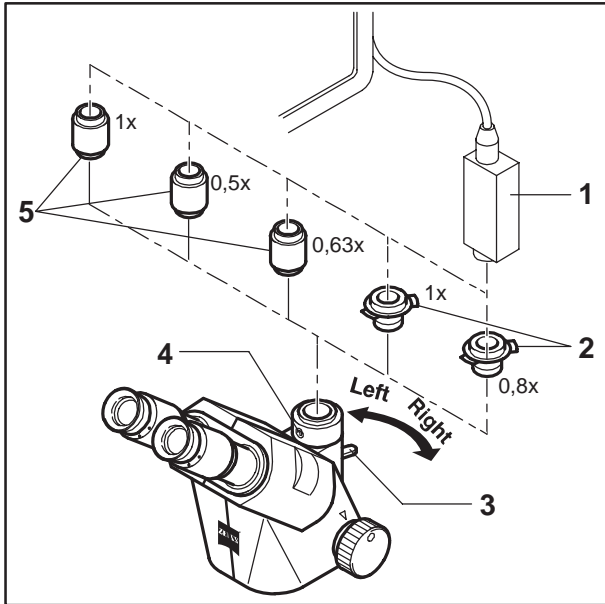

Figure 2-10 Mounting a video camera

(6) Video microscopy

- Depending on the video camera used, adapt the
 - Standard C connection thread (2-10/5)
 - or
 - ENG-bayonet connection (2-10/2)
 to the video camera (2-10/1) used.
- Insert the pre-assembled unit in the camera tube, align it and secure it with the 3 mm hexagon socket screw (2-10/4).
- Adjust the required method of viewing the specimen by means of the changeover switch (2-10/3):
 - Right: camera not connected
 - Left: camera connected.

NOTE With regard to operation of video cameras, pay additional attention to camera manufacturers' instructions.



3 Fluorescence contrast with stereomicroscopes

Additional chapter for the following operating manuals:

- Stemi stereomicroscopes 1000/2000/2000-C/2000-CS and
- Stemi stereomicroscopes SV 6/SV 11/SV 11 Apo

3.1 FL S (Fluorescence for Stereomicroscope) configuration

3.1.1 Name and intended application

With the FL-S configuration, Carl Zeiss provides the possibility of performing fluorescence tasks with stereomicroscopes (regardless of their type).

The features of fluorescence contrast can thus be combined with the benefits of the various stereomicroscope models (orthoscopy, wide object fields and long working distances).

Application examples for the FL S configuration in combination with

Greenough-type stereomicroscopes (Stemi DV: Double Lens Vario)

OR

Telescope-type stereomicroscopes (Stemi SV: Single Lens Vario)

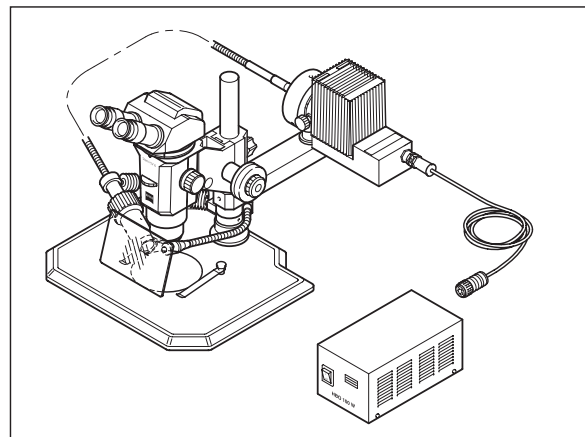
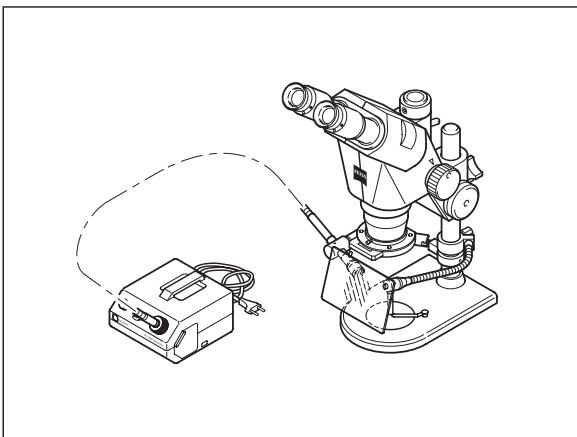

Fig. 3-1 Stemi 2000 with KL 1500 electronic

Fig. 3-2 Stemi SV 6 with HBO 100

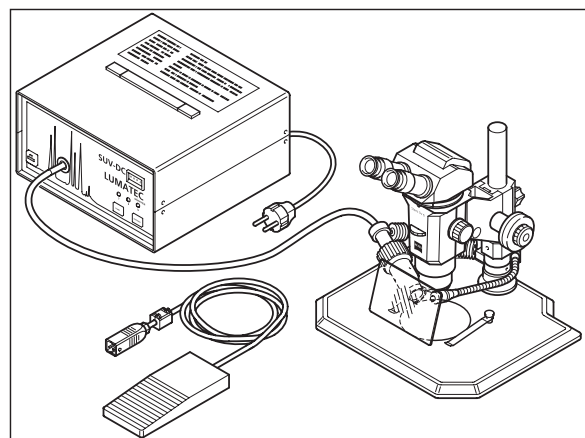
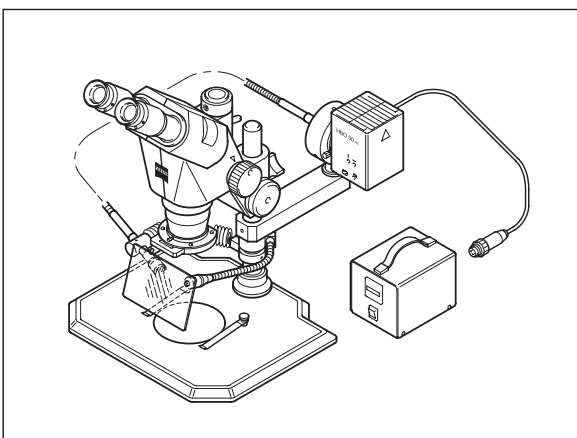

Fig. 3-3 Stemi 2000 with HBO 50

Fig. 3-4 Stemi SV 11 with LUMATEC HBO 200



3.2 Configurations

Regardless of which stereomicroscope is used, different configurations are possible:

No..	Description	Cat.No.	Comments
1	FL S configuration with KL 1500 electronic, consisting of:		
1.1	– Schott cold-light source KL 1500 electronic (230 V) or	495054-9801-000	
1.2	– Schott cold-light source KL 1500 electronic (120 V)	495054-9901-000	
1.3	– Integrated illuminator with light guide and focusing attachment	455145-1014-925	
1.4	– Light guide adapter 10/15		
1.5	– Schott FL S focusing attachment	417088-0000-000	
2	FL S configuration with HBO 50 or HBO 100, consisting of:		
2.1	– mount 32 for HBO 50/100	455188-0000-000	
2.2	– HBO 50 illuminator, consisting of:	487201-9804-000	
2.2.1	– HBO 50 lamp housing incl. lamp mount	447220-0000-000	
2.2.2	– Power unit for HBO 50, 220-240 V, 50-60 Hz, 350 VA	392642-0000-000	
2.3	HBO 100 illuminator, consisting of:	487207-9804-000	
2.3.1	– HBO 100 W/Z lamp housing, incl. lamp mount		
2.3.2	– power unit for HBO 100		
2.4	– collector for light guide	447250-0000-000	
2.5	– FL S liquid light guide, d=8 mm, l=1000 mm	417087-0000-000	
3	FL S configuration with LUMATEC HBO 200, consisting of:		
3.1	SUV-DC-P light source, LUMATEC HBO 200	000000-1023-506	
3.2	FL S liquid light guide, d=8 mm, l=1500 mm	000000-1023-507	
4	Accessories		
4.1	– jointed mount S	000000-1013-082	
4.2.1	– focusing attachment FL S 0.4	000000-1012-895	
4.3	– FL S glare protector	455177-0000-000	
4.4	– Filter sets, each consisting of excitation filter and barrier filter slider		
4.4.1	– UV FL S 02 filter set	000000-1015-034	Standard filter set
4.4.2	– GFP-violet FL S 05 filter set	000000-1015-035	Standard filter set
4.4.3	– GFP-plus FL S 09 filter set	000000-1015-036	Standard filter set
4.4.4	– GFP-blue FL S 13 filter set	000000-1015-037	Standard filter set
4.4.5	– FL S 15 green filter set	000000-1015-038	Standard filter set
4.4.6	– UV special FL S 02 HT filter set	000000-1017-341	LUMATEC HBO 200
4.4.7	– GFP-violet special FL S 05 HT filter set	000000-1017-342	LUMATEC HBO 200
4.4.8	– GFP-plus special FL S 09 HT filter set	000000-1017-343	LUMATEC HBO 200
4.4.9	– Empty mount for excitation filter dia. 18	000000-1013-083	customer's choice
4.4.10	– Empty mount for 1x barrier filter dia. 45	000000-1013-085	customer's choice
4.4.11	– Empty mount for 2x barrier filter dia. 25	000000-1013-084	customer's choice
4.5	– FL S barrier filter mount for Stemi DV (Double Lens Vario)	455031-0000-000	Stemi 1000/2000
4.6	– FL S barrier filter tube for Stemi SV (Single Lens Vario)	455176-0000-000	SV6/11/11 Apo

3.2.1 FL S configuration with KL 1500 electronic (not suitable for UV excitation)

Stemi 1000 / 2000 / 2000 C / 2000 CS
(in Stemi mount)

Stemi SV 6 / SV 11 / SV 11 Apo
(with Stemi mount)

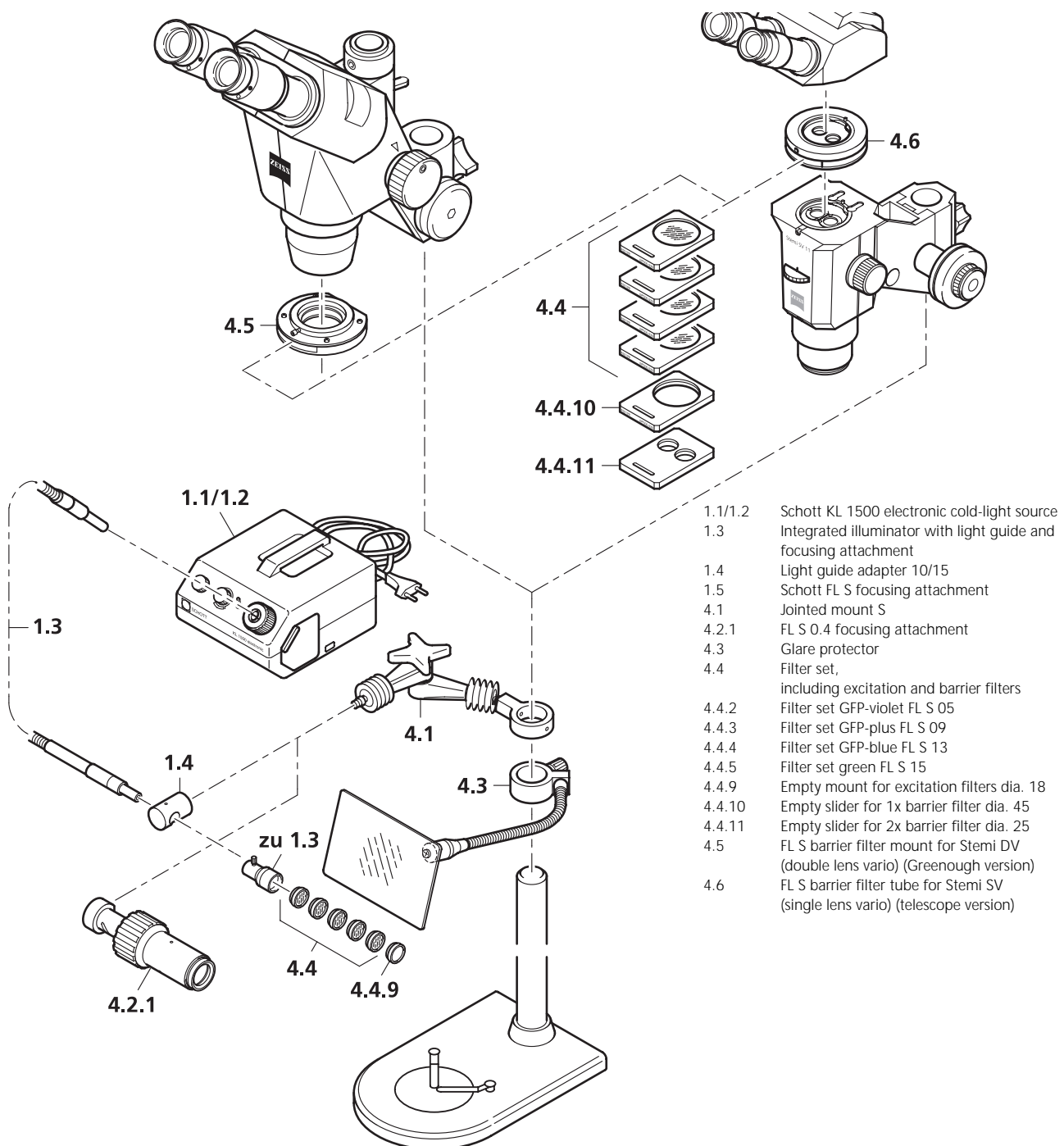

Fig. 3-5 FL S configuration with KL 1500 electronic

- Remove microscope body with Stemi carrier (6/2) and safety ring (6/3) from the stand S (6/4).
- Attach jointed mount S (6/1) and FL S glare protector (6/5) to the stand column.
- Place Schott KL 1500 electronic cold-light source (7/8) in position.
- Connect integrated light guide (7/1) to the cold-light source.
- Screw excitation filter (7/5) in the used focusing attachment (7/4 or 6).
- Attach end of integrated light guide (7/2) to jointed mount S (7/3) via light guide adapter 10/15 (7/7), attach focusing attachment (7/6) and clamp it.
- Attach focusing attachment (7/4) directly to jointed mount S (7/3).

NOTE

For the installation of the light guide and for the filter change please see the separate notes on page 3-10.

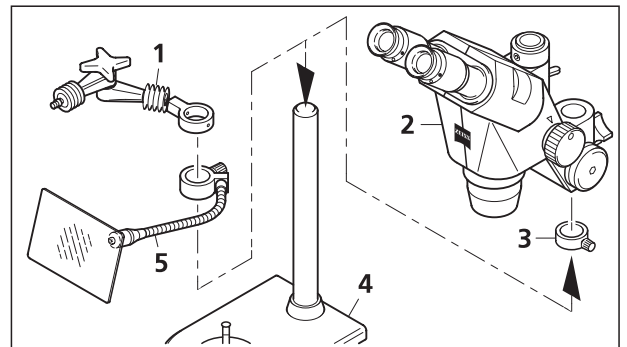

Fig. 3-6

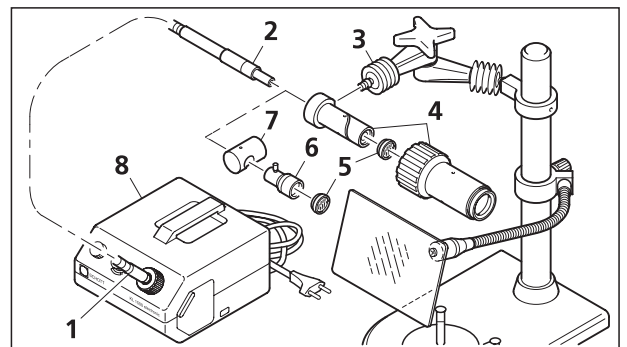

Fig. 3-7

- Attach microscope body (8/1) and, if required, safety ring (8/2) to the stand again.
- When using a Double Lens Vario microscope (Stemi 1000/ 2000), screw Allen screw (8/6) to the receptacle with dia. 53 using the screwdriver (8/5) to attach the barrier filter mount FL S (8/3).
- Push required barrier filter (8/4) into the barrier filter mount. (KL 1500 electronic not suitable for UV excitation!)
- Switch on KL 1500 electronic (9/7), align the luminous field diameter with the required object field and optimize illuminance through focusing and variations of the working distance.
- Adjust glare protector (9/6) for glare-free microscopy.

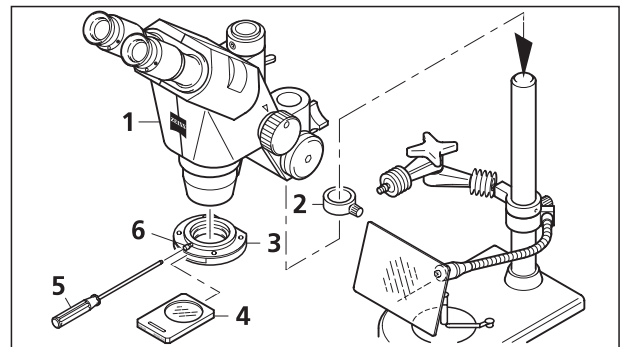

Fig. 3-8

- When using a Single Lens Vario microscope (SV 6/11), first remove the binocular tube (9/3) by unscrewing Allen screw (9/4).
- Insert the FL S barrier filter tube (9/2) between the microscope body (9/5) and the binocular tube (9/3).
- Attach the binocular tube to the barrier filter tube.
- Push required barrier filter slider (9/1) into the barrier filter tube.
- Switch on KL 1500 electronic (9/7), align the luminous field diameter with the required object field and optimize illuminance through focusing and variations of the working distance.
- Adjust glare protector (9/6) for glare-free microscopy.

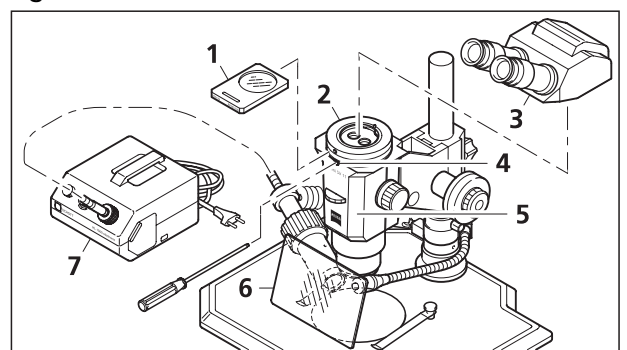

Fig. 3-9

3.2.2 FL S configuration with HBO 50 or HBO 100

**Stemi 1000 / 2000 / 2000 C / 2000 CS
(in Stemi mount)**

**Stemi SV 6 / SV 11 / SV 11 Apo
(with Stemi mount)**

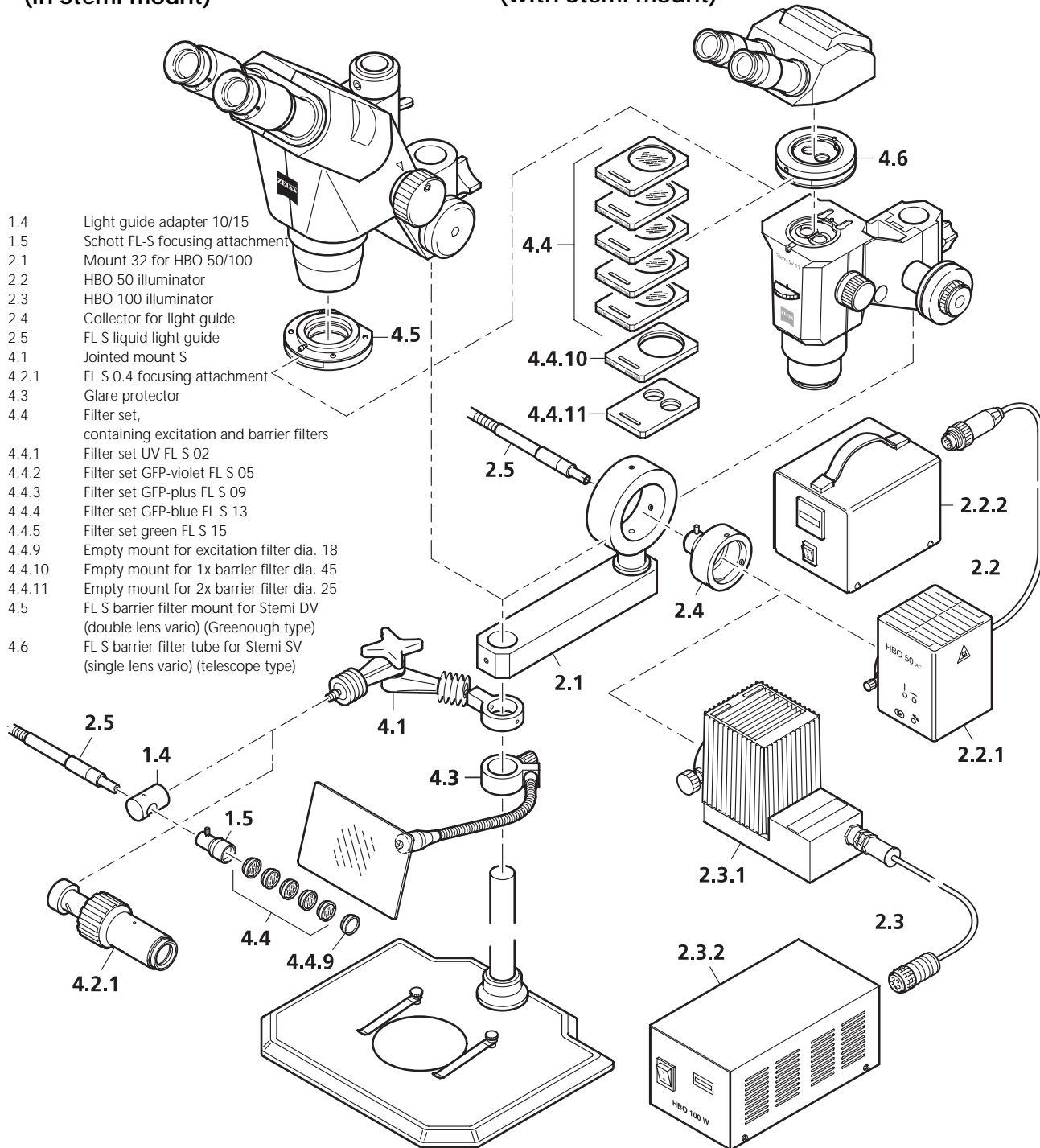

Fig. 3-10 FL S configuration with HBO 50 or HBO 100

- Remove microscope body (with Stemi carrier) (11/2) and safety ring (11/3) from stand N (11/4).
- Attach jointed mount S (11/6) and FL S glare protector (11/5) to the stand column.
- Also attach mount 32 for HBO (11/1) to the stand column.
- Adjust HBO 50/100 to ∞ in accordance with the operating instructions.
- Remove the dovetail from the HBO 50/100, then use 3 Allen screws to attach the collector for the light guide (12/4) to the HBO 50 (12/5) or HBO 100 (12/6).
- Attach collector with attached lamp housing to mount 32 for HBO (12/2) (3 Allen screws).
- Use fixation screw (12/3) to fix the liquid light guide (12/1) to the collector.

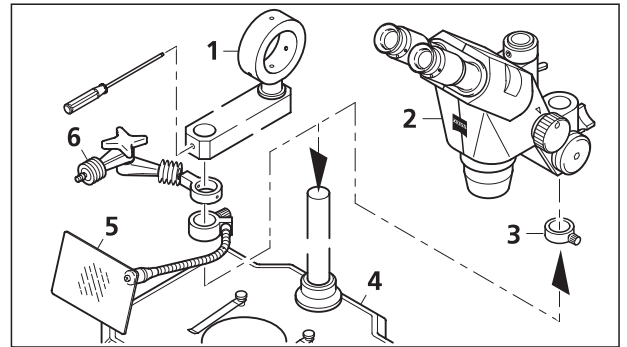

Fig. 3-11

- Screw excitation filter (12/8) into the focusing attachment used (12/7 or 9).

NOTE

For the installation of the light guide and for the filter change please see the separate notes on page 3-10.

- Attach liquid light guide (12/1) to the jointed mount S (12/11) via light guide adapter 10/15 (12/10), attach focusing attachment (12/9) and clamp it.
- Attach focusing attachment (12/7) directly to the jointed mount S (12/11).

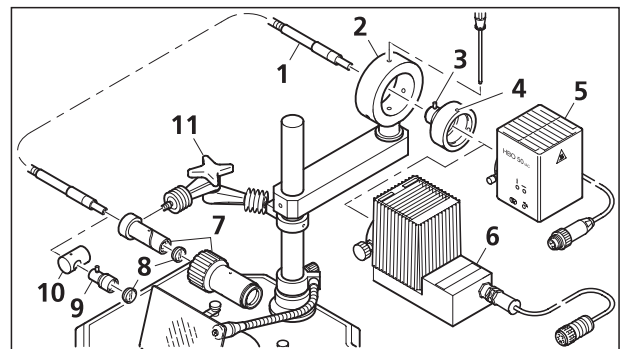

Fig. 3-12

- Attach microscope body (13/1) and, if required, safety ring (13/2) to the stand again.
- Connect lamp housing of the used illuminator to the relevant power unit (13/3 or 4) and connect the power unit to the line.

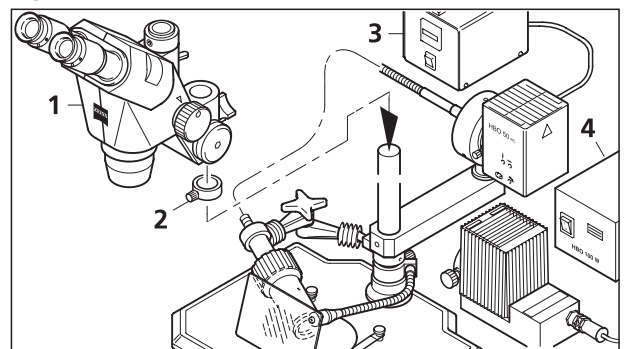

Fig. 3-13

- Depending on the used microscope version, attach FL-S barrier filter mount (14/1) for the DV-version or FL S barrier filter mount (14/2) for the SV-version together with the required barrier filter slider (14/3) (for a detailed description please see Figs 3-8 and 3-9).

NOTE

For UV excitation, please remember to use the barrier filter slider (protects your eyes from reflecting/scattered UV excitation light)!

- Switch on illuminator (HBO 50 or HBO 100), align the luminous field diameter with the required object field and optimize illuminance through focusing and variations of the working distance.

- Adjust glare protector (14/4) for glare-free microscopy.

CAUTION

Glare to the eyes and direct irradiation of the skin with excitation light must be avoided.

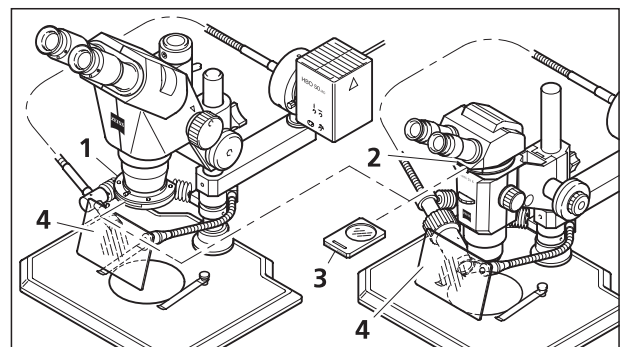

Fig. 3-14

3.2.3 FL S configuration with LUMATEC HBO 200

Stemi 1000 / 2000 / 2000 C / 2000 CS
(in Stemi mount)

Stemi SV 6 / SV 11 / SV 11 Apo
(with Stemi mount)

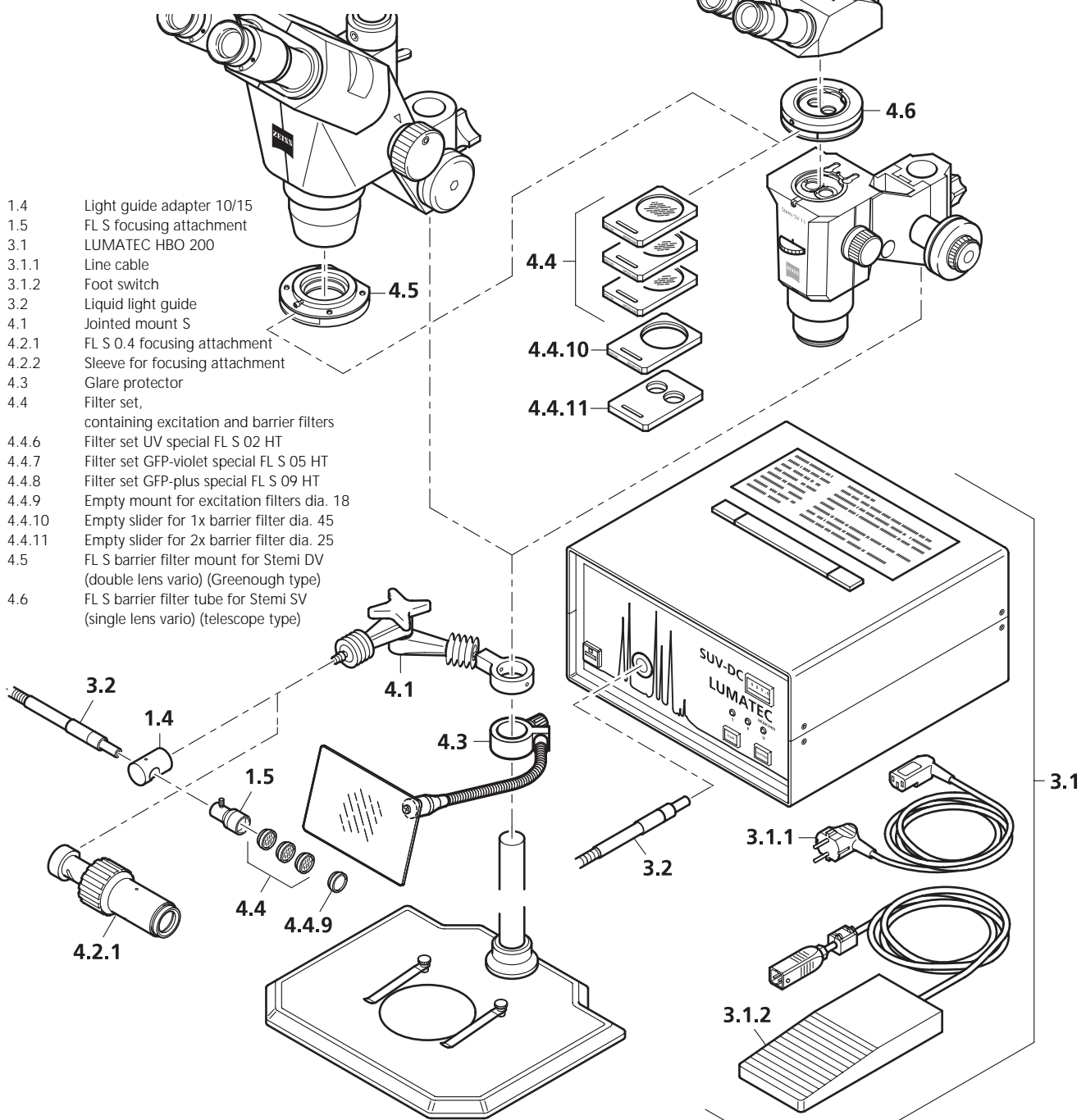

Fig. 3-15 FL S configuration with LUMATEC HBO 200

- Remove microscope body with Stemi mount (16/4) and safety ring (16/5) from stand N (16/3).
- Attach jointed mount S (16/1) and FL S glare protector (16/2) to the stand column.
- Then attach microscope body to the stand column again.

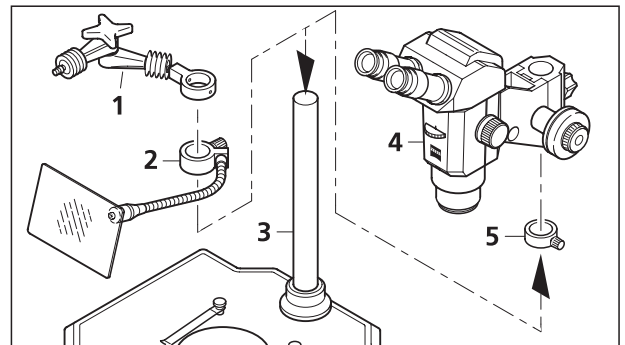

Fig. 3-16

- Place LUMATEC HBO 200 SUV-DC-P light source (17/2) in position, connect foot switch (17/4) to the instrument rear, connect the unit to the line via line cable (17/3) (also see the LUMATEC HBO 200 operation manual and the safety notes included!).
- Connect the liquid light guide (17/1) to the front of the LUMATEC HBO 200 light source (use liquid light guide of 1500 mm length with special connector for LUMATEC HBO 200).
- Screw temperature-resistant special excitation filter (18/3) into the used focusing attachment (18/2 or 4).
- Attach liquid light guide (18/6) to jointed mount S (18/5) via light guide adapter 10/15 (18/1), attach focusing attachment (18/2) and clamp it.

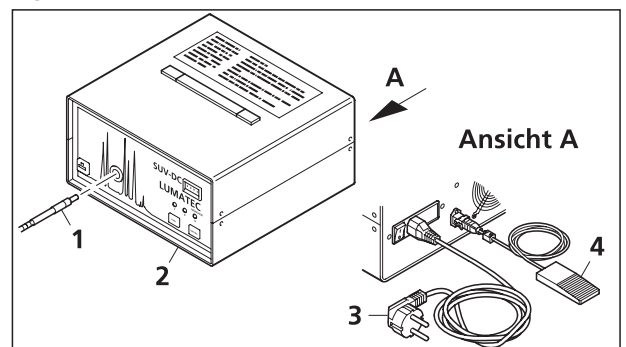

Fig. 3-17

- Attach focusing attachment (18/4) directly to the jointed mount S (18/5).

NOTE

For the installation of the light guide and for the filter change please see the separate notes on page 3-10.

- Depending on the used microscope version, attach FL-S barrier filter mount (19/1) for the DV-version or FL S barrier filter mount (19/2) for the SV-version together with the required barrier filter slider (14/3) (for a detailed description please see Figs 3-8 and 3-9).

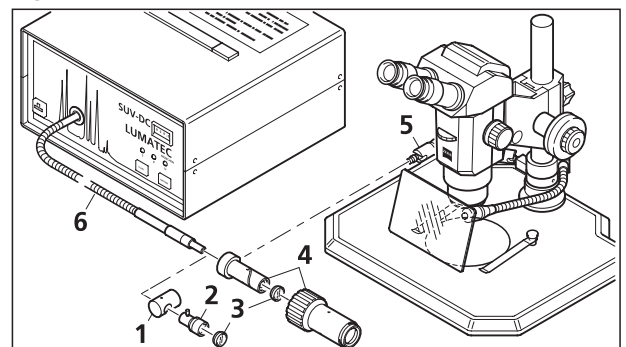

Fig. 3-18

CAUTION Only use the temperature-resistant special filter sets for the LUMATEC HBO 200.

NOTE For UV excitation, please remember to use the barrier filter slider (protects your eyes from reflecting/scattered UV excitation light)!

- Switch on LUMATEC HBO 200 illuminator in accordance with the instrument manual, align the luminous field diameter with the required object field and optimize illuminance through focusing and variations of the working distance.
- Adjust glare protector (19/4) for glare-free microscopy.

CAUTION Glare to the eyes and direct irradiation of the skin with excitation light must be avoided. If excitation is not required, close the shutter which is integrated in the LUMATEC HBO 200.

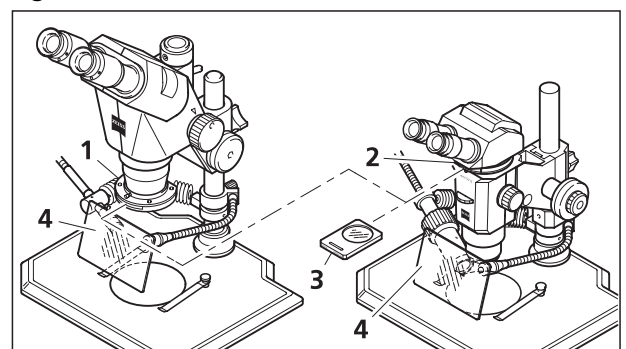

Fig. 3-19

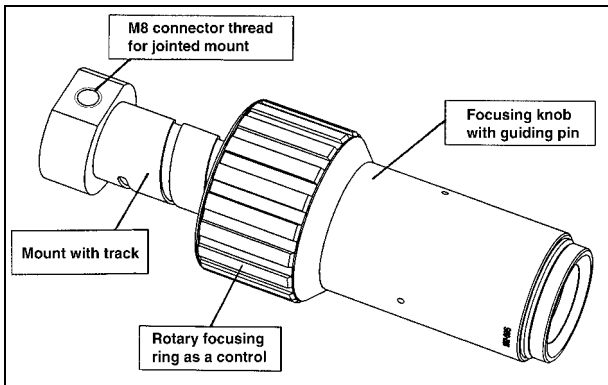

Fig. 3-20

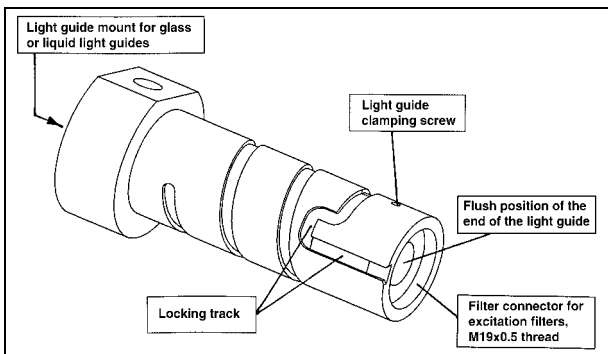

Fig. 3-21

NOTES

- For installation of the light guide and for filter change, the focusing head must be separated from the mount. To unlock the focusing attachment, push it through the track until the end. Then slightly push back the focusing knob at the bottom end of the track, slightly turn it and remove it in forward direction (also see Figs 3-20 and 3-21).
- To mount the light guide, push the end of the light guide into the light guide mount until it is flush with the inner plane surface of the excitation filter connector, and carefully clamp it using the clamping screw and the enclosed Allen key (also see Fig. 3-21).

4 Care and troubleshooting

4.1 Care

Care of the stereo microscope is limited to the following:

- Cover the unit with the dust cover after every use.
- Do not place the unit in a humid room.
- Cover open tubes with dust caps.
- Remove dust from optical surfaces with a rubber blower or with a natural hair brush. Degrease the brush in alcohol and then dry it. Remove stubborn soiling and fingerprints with a dust-free cloth or leather.
- Use commercially available optical and spectacle cleaning cloths to remove extreme soiling (e.g. fingerprints) from optical surfaces; if necessary, moisten cloths lightly with petroleum ether. If necessary, clean the front surfaces of lenses with petroleum ether, but do not use any alcohol.

Pay attention to the following notes when using the Stemi in moist and warm climates:

- Store the Stemi in bright, dry and well ventilated rooms with a humidity less than 65 %; store particularly sensitive modules and accessories such as lenses and eyepieces in dry cabinets.
- When storing the microscope or its parts in closed receptacles for longer periods of time, fungi can largely be avoided by placing absorbent substances soaked in fungicide in the receptacles.

IMPORTANT Fine mechanical and optical devices are always at a risk of fungus affection under the following conditions:

- relative humidity > 75 % for more than three days at temperatures from + 15 °C to +35 °C.
- placing them in dark rooms where there is no movement of air and
- in the event of dust deposits and fingerprints on optical surfaces.

4.2 Troubleshooting and service

Troubleshooting on the Stemis is limited to few activities:

- Checking of the power supplies.
- Checking of the illuminating devices.

(1) Checking of the power supplies

The checking of the power supplies is limited to the inspection of the fuses in:

- ☞ Power supply 230 V – 6 V 50 VA, order No. 458420
fuse: T 400mA/L 250 V (5 x 20) mm acc. IEC 127
- ☞ Power supply 120 V – 6 V 50 VA, order No. 458421
fuse: T 500mA/L 250 V (5 x 20) mm acc. IEC 127
- ☞ Power supply unit, established 6 V 20 W, 115 – 230 V,
variable 1,5 ... 6 V, 50 ... 60 Hz, 40 VA, order No. 458415
fuse: T 4,0 A/H 250 V (5 x 20) mm acc. IEC 127
- ☞ Schott cold light source KL 750 (230 V), order No. 417080
fuse: T 630 mA/L 250 V (5 x 20) mm acc. IEC 127
- ☞ Schott cold light source KL 750 (120 V), order No. 417081
fuse: T 1,25 A/H 250 V (5 x 20) mm acc. IEC 127
- ☞ Schott cold light source KL 1500 electronic (230 V), order No. 417075
fuse; primary: T 2 A/H 250 V (5 x 20) mm acc. IEC 127
secondary: T 10 A/H 250 V (5 x 20) mm acc. IEC 127
- ☞ Schott cold light source KL 1500 electronic (120 V), order No. 417076
fuse; primary: T 4 A/H 250 V (5 x 20) mm acc. IEC 127
secondary: T 10 A/H 250 V (5 x 20) mm acc. IEC 127.

When checking the power supplies, also check the mains cables. Defective cables must be replaced.

(2) Checking of the illuminating devices

Check the illuminating devices including a check of the power supply units used (switch settings, mains connection) and if necessary, replace the halogen lamp.

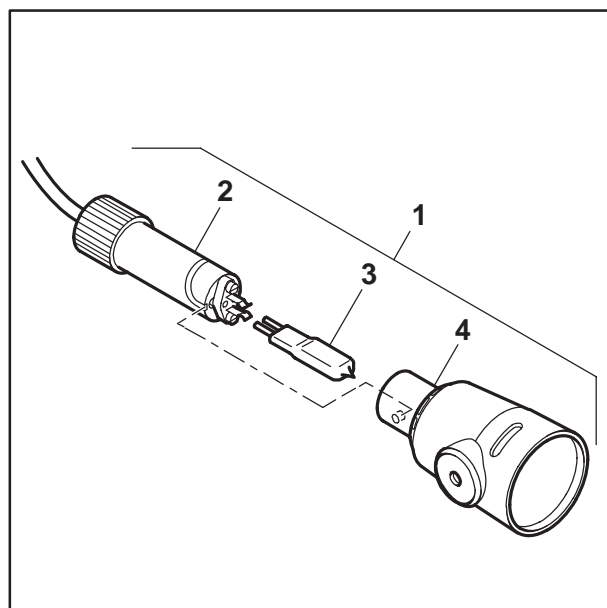

Figure 4-1 Lamp replacement

- Isolate the lighting unit (4-1/1) from the mains.
- Undo the lamp housing (4-1/4) from the lamp holder (4-1/2) by turning it lightly to the left.
- Pull the defective halogen lamp (4-1/3) out of the lamp holder and replace it by a new halogen lamp of the same type (6 V 10 W).

IMPORTANT Do not touch lamp bulbs with your bare hands; if necessary, clean the bulb **before** the first use with pure alcohol to prevent baking in of soiling.

(3) Service

All tampering on optical parts or motion elements in the interior of the unit or on the power supply may only be carried out by service specialists or specially **authorised** personnel.

For servicing, contact your nearest regional representative or

Carl Zeiss Jena GmbH
 Zeiss Gruppe
 Unternehmensbereich Mikroskopie
 Tatzendpromenade 1a
 D-07745 Jena

Telefon: (03641) 64-2936
 Telefax: (03641) 64-3144
 Internet: micro@zeiss.de
<http://www.zeiss.de>



Stemi 1000, Stemi 2000, Stemi 2000-C



ANNEX

- List of abbreviations A-3
- Certification in accordance with DIN ISO 9001/EN 29001/EN 46001 A-5
- EC conformity declaration A-7



Stemi 1000, Stemi 2000, Stemi 2000-C

List of abbreviations

B & L b/w	Bausch and Lomb Black & white
CTV	<u>C</u> olour <u>T</u> elevisi <u>o</u> n
EN ENG	European standard <u>E</u> lectronic <u>N</u> ews <u>G</u> athering
foc. FOD	Capable of focusing Free operating distance
HAL	Halogen
IEC IP ISO	International <u>E</u> lectrotechnical <u>C</u> ommission International <u>P</u> rotection International <u>O</u> rganization for <u>S</u> tandardization
MC mf	<u>M</u> icroscope <u>C</u> amera Microphotography
SK SLR Spect. Stemi	Class of protection <u>S</u> ingle <u>L</u> ens <u>R</u> eflex Spectacles Stereo microscope
TV	Television
W W-PL	Wide field Wide field, plane



Stemi 1000, Stemi 2000, Stemi 2000-C
